

5117# HB 油壓增壓器 TC. SP 用低壓轉高壓 Hydraulic Booster

產品簡介

- 本產品機構內附油壓順序閥，預壓式特性操作時可將作動缸充滿油，達到預先設定之壓力順序閥動作，即可獲得倍數增壓。
- 適用於油壓專用機，MC 治具低壓迴路中，部份油壓缸需高壓操作之場合，僅需一只電磁閥或安裝於管路中，即可操作HB增壓器，可將低油壓自動轉換成高油壓，獲得高壓夾持。

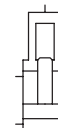

Product Introduction

- A hydraulic sequential valve is attached to the structure of this unit. When operating, it may oil to cylinder and makes it be at the dual pressure and let the sequential valve act, and then it will provide multiple boosting pressure.
- It's fit for hydraulic special purpose machine and MC clamp in low pressure circuit, It needs a solenoid valve installed in the circuit, and then it will be able to operate HB super-charger. The super-charger may be converted automatically from low oil-pressure to high oil-pressure and obtain a high pressure clamping.

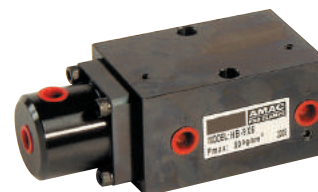

**最高操作壓力50kg/cm²
Max. operation pressure**

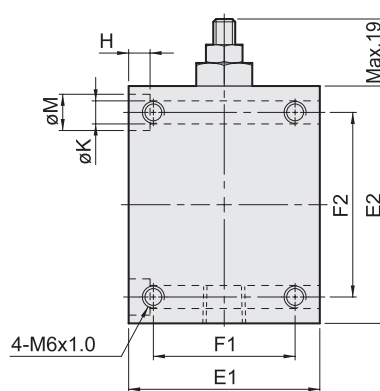
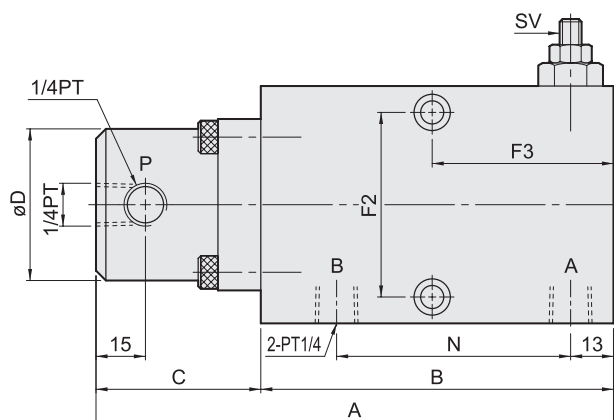

迴路圖 Circuit diagram

Model	HB-9×6	HB-8×22	HB-5×35	HB-3.8×45
增高倍出 Multiple boost	9	8	5	3.8
高壓吐油量 High pressure output	6cc	22cc	35cc	45cc
A	157		210	
B	107		139	
C	50		71	
D	φ46		φ58	
E1	58		82	
E2	72		100	
F1	43		62	
F2	56		80	
F3	55		70	
H	7		9	
K	φ7		φ9	
M	φ11		φ14	
N	71		96	

