

5101# 精密油壓齒式分割台 Hydraulic Coupling Gear Indexer



特性：

- 油壓齒式分割台使用三片式齒盤做分割定位，在執行分割動作時盤面沒有升降動作，所以具有高鋼性且耐重切割。
- Three pieces of Hirth coupling gears are built inside positioning and indexing, there is no floating action during degree indexing. Whole-closed structure design has high rigidity and gripping force increase the efficiency greatly during heavy duty cutting.

型式 Model		HCT-200	HCT-340	HCT-470	HCT-600	HCT-800	HCT-1000
盤面直徑 Table diameter	mm	φ 200	φ 340	φ 470	φ 600	φ 800	φ 1000
基準中心孔Center bore	mm	φ 36 H6	φ 65 H6	φ 90 H6	φ 110 H6	φ 120 H6	φ 120 H7
基準中心孔深度Depth of center bore	mm	30	11	11	11	40	60
主軸中心穿透孔 Diameter of center through hole	mm	φ 27	φ 30.5	φ 41	φ 53	φ 80	φ 80
水平放置總高 Overall height (Horizontally)	mm	175	210	240	260	305	325
油壓使用壓力 Hydraulic pressure	kg/cm ²	30	30	35	35	35	35
分割精度(累積值) Indexing accuracy (accumulative)	arc sec	4"	4"	4"	4"	4"	4"
重現精度 Repeatability	arc sec	1±"	1±"	1±"	1±"	1±"	1±"
分割台等分割數(標準) Indexing number (standard)		4 / 6 / 8 / 12 / 24 (擇一One of them)					
分割台等分割數(特殊) Indexing number (special)		2 / 3 / 5 / 9 ... 接受特殊等分訂購 By special order					
旋轉方向 Rotating direction		正反轉皆可 CW & CCW					
旋轉90°的時間方向 Indexing time of 90°	sec	2	2.5	3.5	6.0	10	10
容許瞬間慣性 GD ² Permissible instant inertia GD ²	kg/m ²	7	85	180	500	1000	1200
旋轉扭力 Rotation torque	kg-m	25	57	86	144	280	280
鎖緊扭力 Clamping torque	F	kg N	1260 12340	1560 15200	3970 38500	6448 63000	9600 94000
	F×R	kg-m N-m	108 1060	332 3250	1428 13390	1980 19400	4000 39200
	F×H	kg-m N-m	55 541	145 1423	550 5390	840 8232	1950 19110
容許積載荷重 Load Capacity	0°	kg	120	500	700	1250	2400
淨重 Net weight	kg	46	120	266	446	816	1500
*旋轉90°的時間(鬆開、旋轉、鎖緊)係指在使用壓力30kg/cm ² 、2HP、30L/min...等條件下的測試值 Indexing time 90° (Unclamp, rotate, clamp) is measured under the condition of 30 kg/cm ² , 2HP, 30L/min, etc.							

5101# 精密油壓齒式分割台 Hydraulic Coupling Gear Indexer

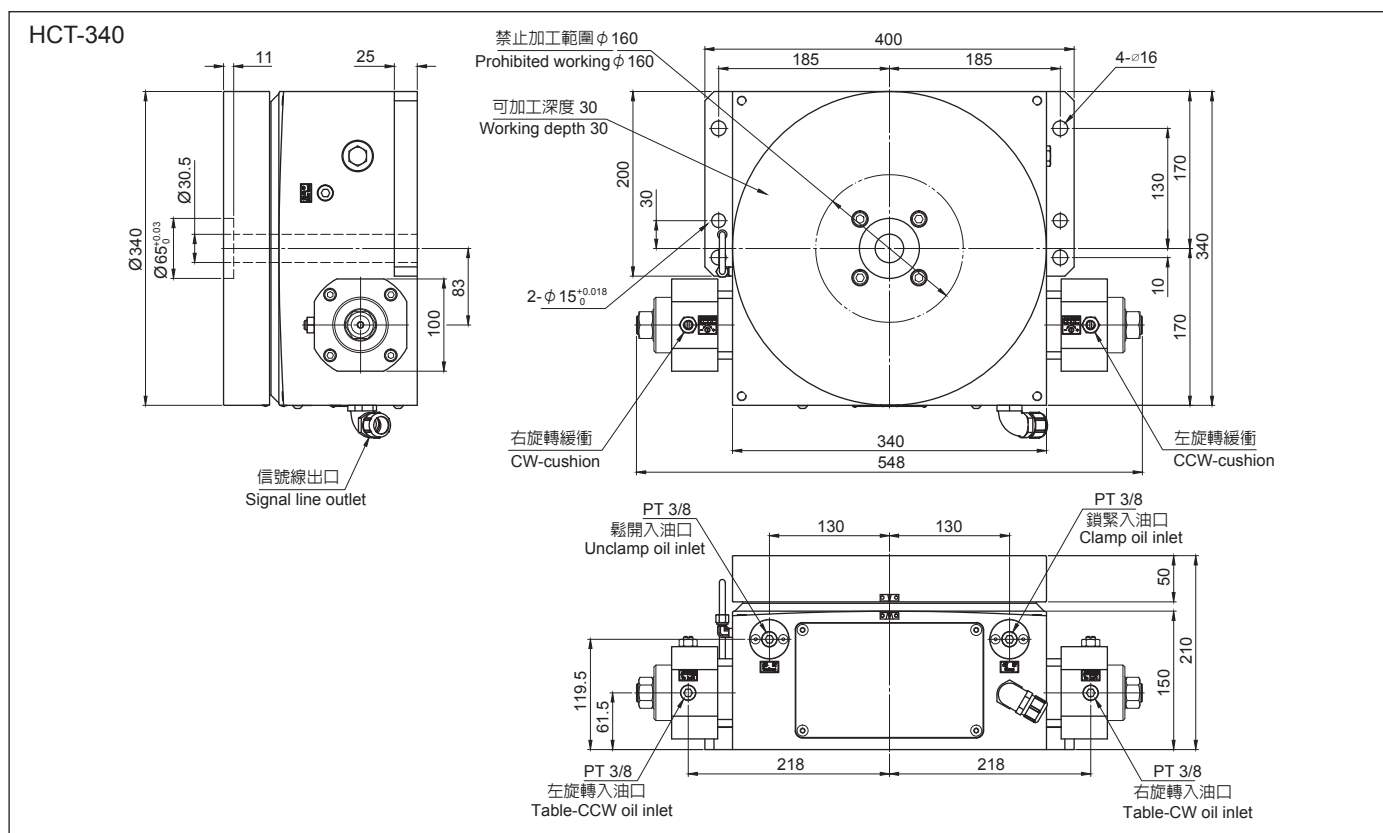
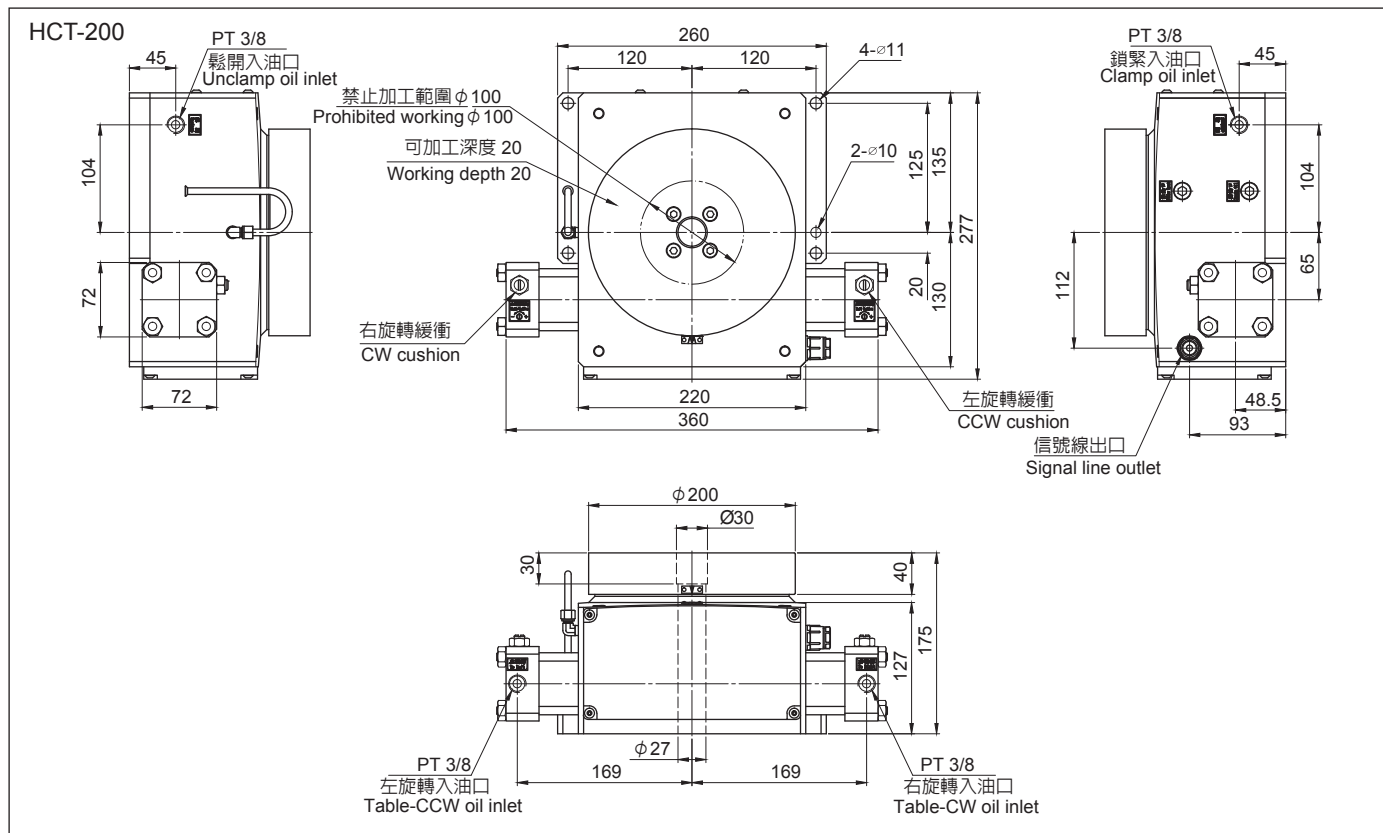

5101# 精密油壓齒式分割台 Hydraulic Coupling Gear Indexer

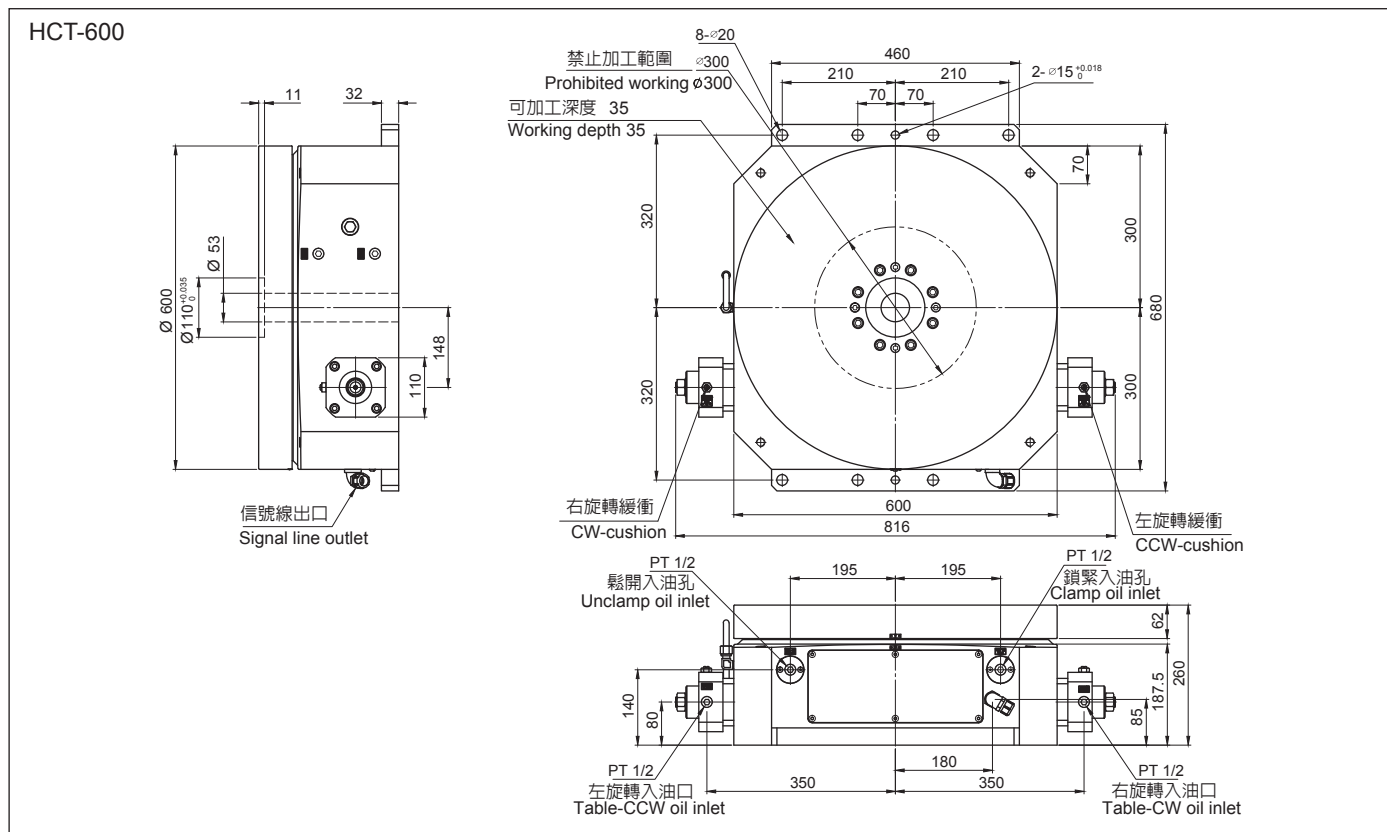
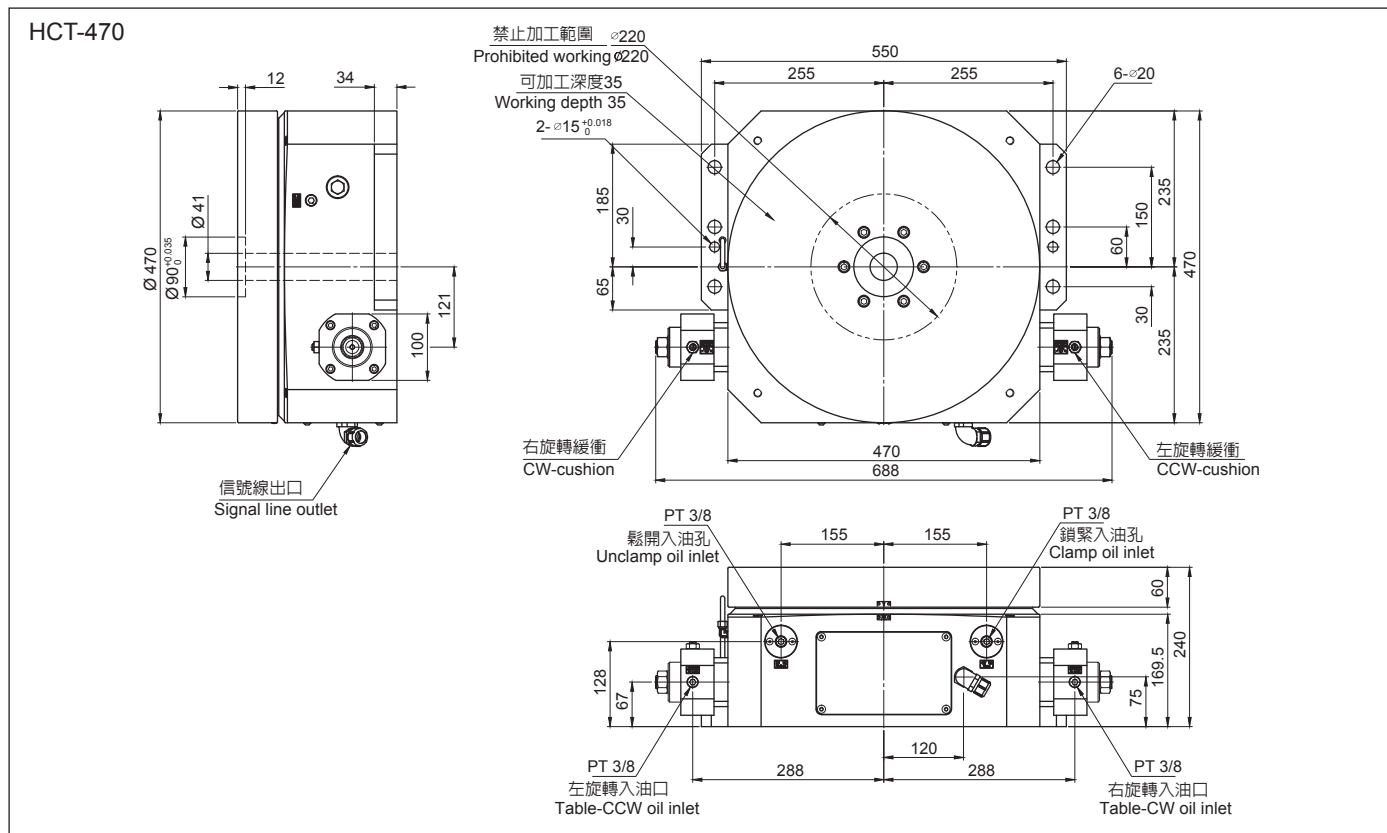

5101# 精密油壓齒式分割台 Hydraulic Coupling Gear Indexer

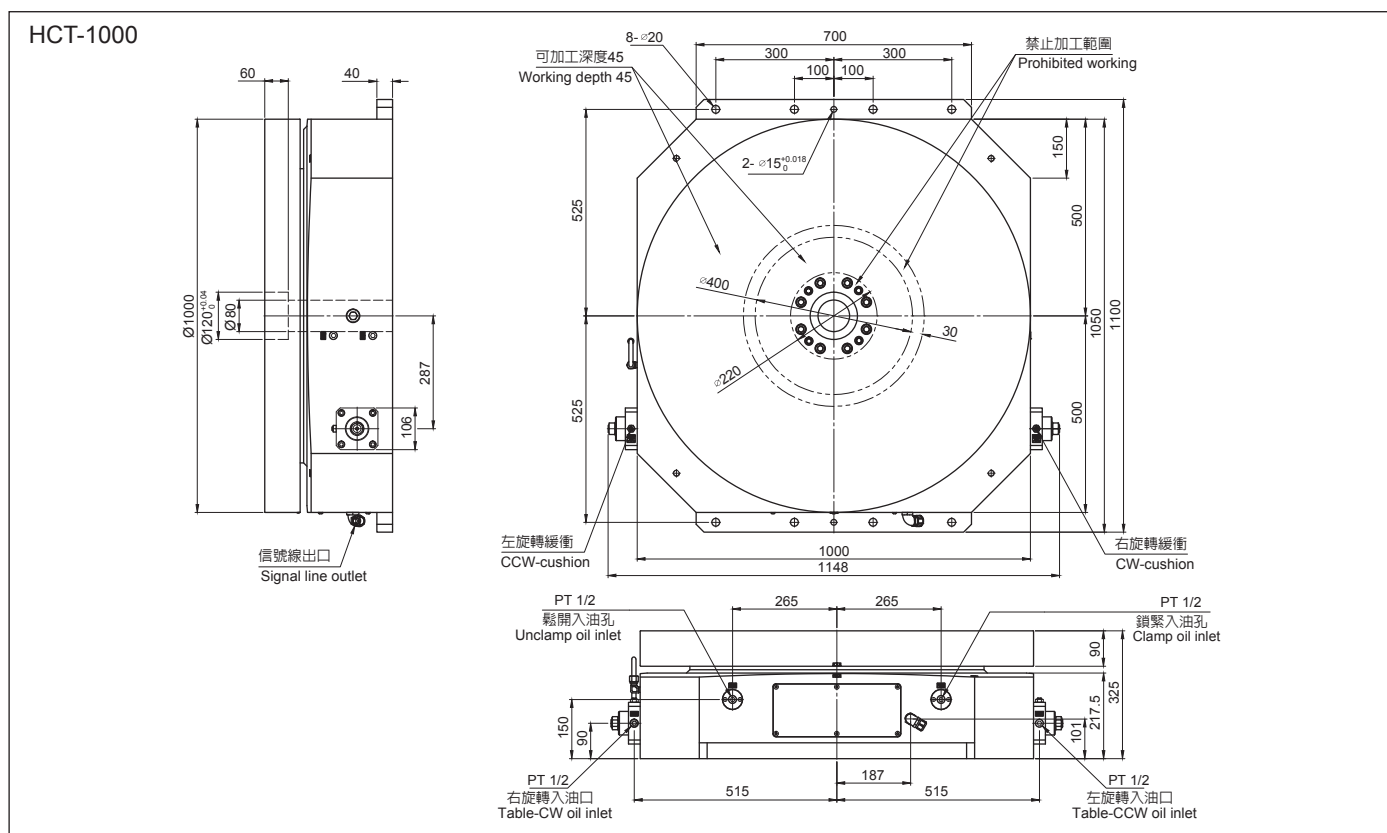
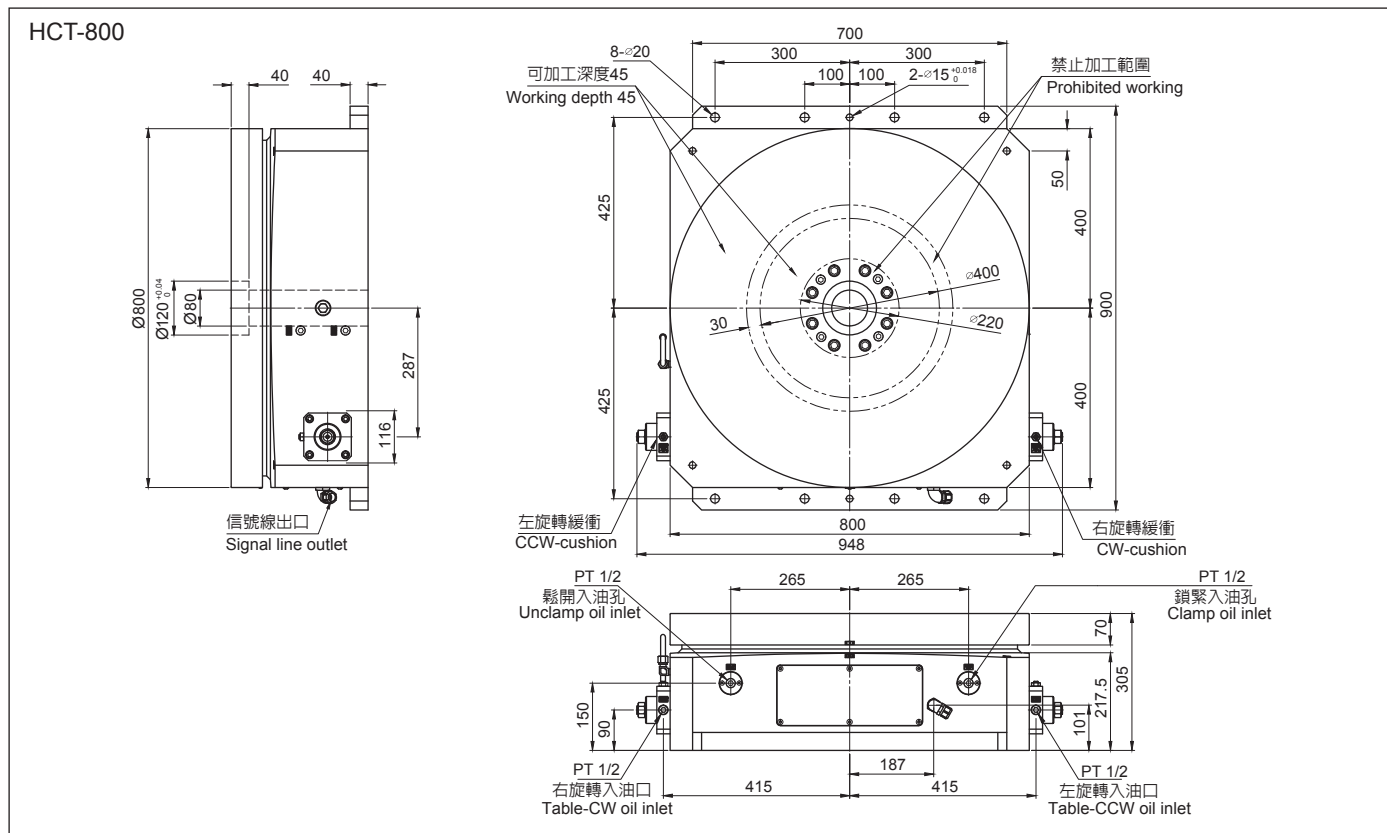

標準精度檢驗項目 Accuracy Standard

項次 No.	檢驗項目 Inspection Items
1	盤面真直度 Straightness of Table top
2	盤面旋轉起伏 Runout of Table top
3	基準中心旋轉偏擺 Runout of center bore
4	分度盤上下面平行度 Parallelism of table top to frame bottom
5	分割精度(光學儀器測量) Indexing accuracy (arc sec) -- measured by an optical measuring device

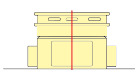
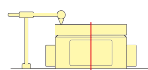
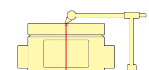
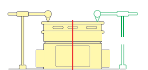
型式 Model	1	2	3	4	5
					分割精度 Indexing accuracy (arc sec)
HCT-200	0.02	0.015	0.02	0.02	4"
HCT-340	0.02	0.015	0.02	0.02	4"
HCT-470	0.02	0.02	0.02	0.02	4"
HCT-600	0.02	0.02	0.02	0.03	4"
HCT-800	0.02	0.02	0.02	0.03	4"
HCT-1000	0.02	0.03	0.02	0.03	4"