

鼻端介面	Spindle Nose	A2-5
主軸外徑	Housing OD	170 (mm)
最高轉速	Maximum RPM	5000
主軸通孔	Through Hole	φ 56
前軸承	Front Bearing	7018×3 φ 90
後軸承	Rear Bearing	7016×2 φ 80
主軸潤滑	Lubrication	油脂 (Grease)
皮帶輪	Spindle Pulley	8YU-44T
編碼輪	Encoder Pulley	HTD 8M-40T
主軸溫升	Rising Temperature	≤ 20°C
平衡	Balancing	ISO 1940 G1
運轉精度	Accuracy	2μm
重量	Weight	61 kgs

HDT170 (A2-5)

重量	Weight	61 kg
----	--------	-------

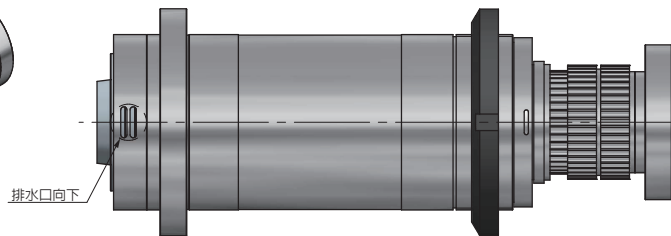
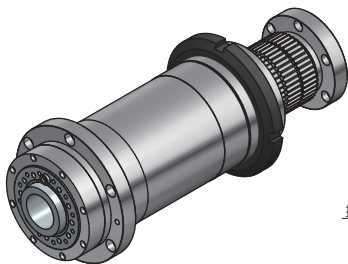
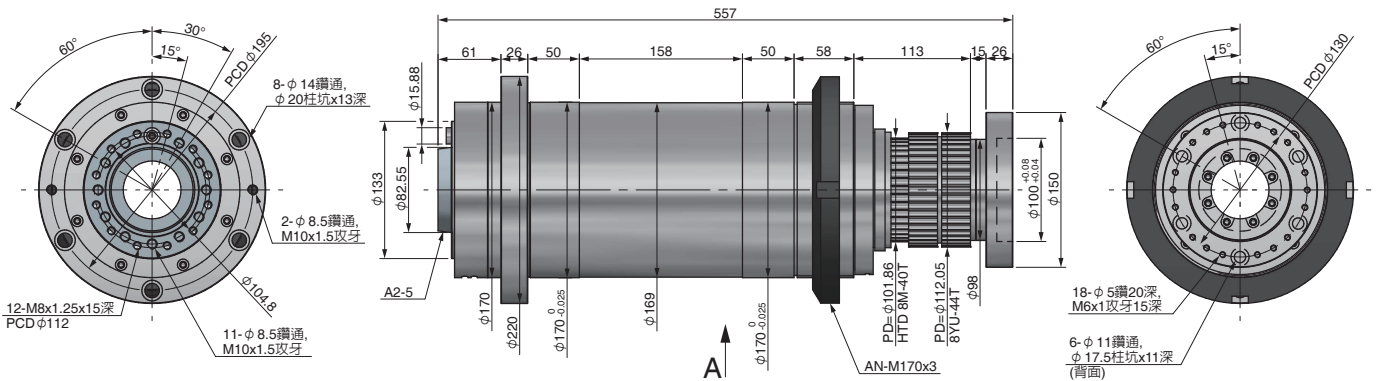

視圖A