

5090# 油壓滑台 (附油缸與流量閥) Hydraulic Slide Units

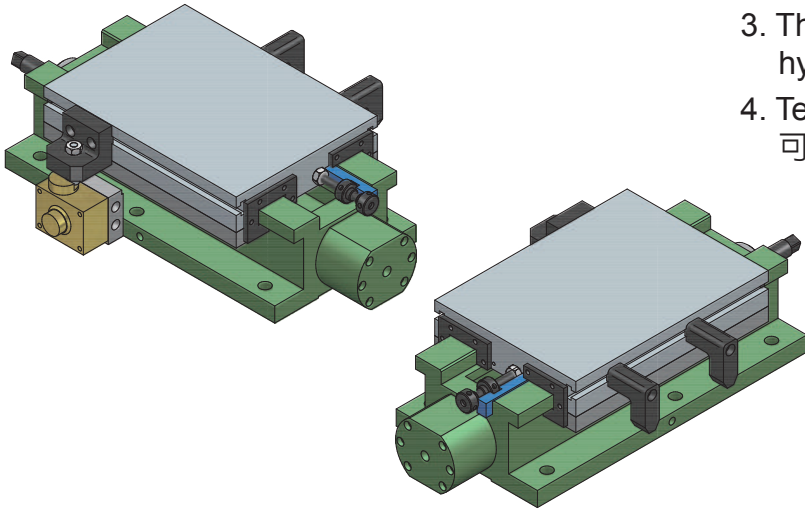

1. Use high tensile cast iron normalied and stress relieved.
2. Slide-way hardened ground.
3. This unit can be driven by automated hydraulic power pack.
4. Telescopic covers (optional)
可另購防塵伸縮/固定護蓋

5090# 油壓滑台 (150) Hydraulic Slide Units (150)

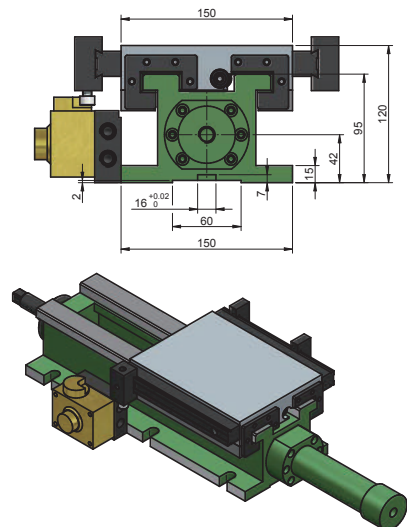
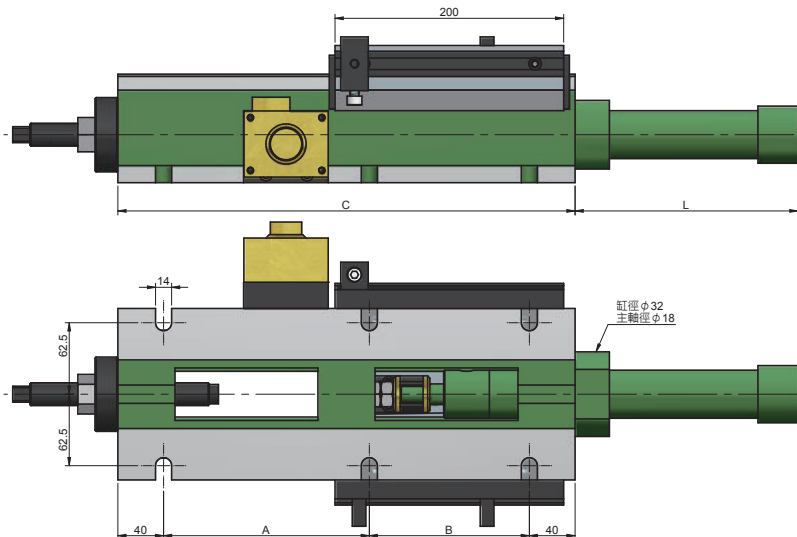

※可訂製滾珠螺桿伺服傳動 (BS系列)

單位：mm

規格 Model	A	B	C	L	行程 Travel	重量 Weight
HS150-200/300	220	—	300	85	80	37
HS150-200/400	180	140	400	195	180	45