

5090# 油壓滑台 (250) Hydraulic Slide Units (250)

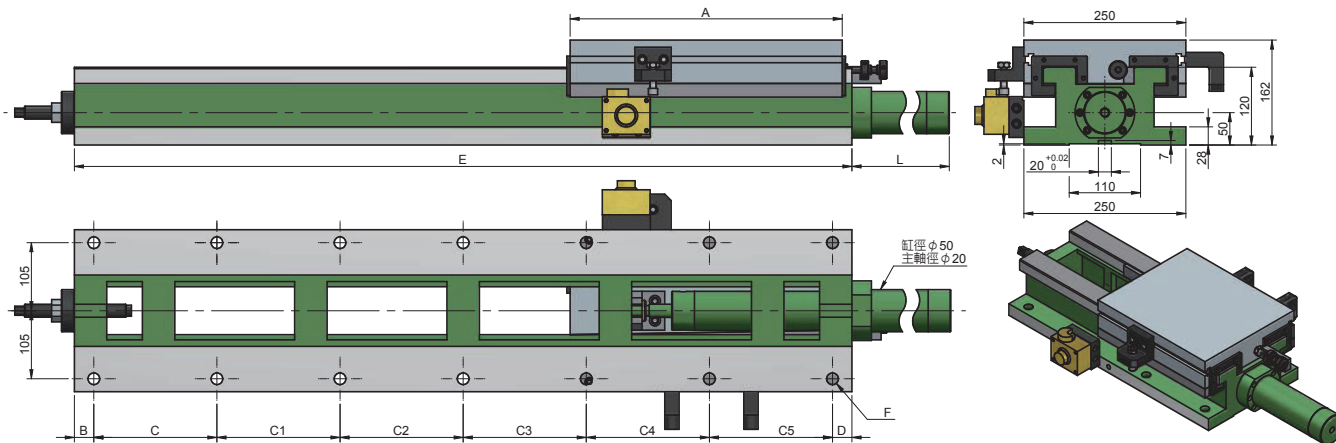

※可訂製滾珠螺桿伺服傳動 (BS系列)

單位 : mm

規格 Model	A	B	C	C1	C2	C3	C4	C5	D	E	F	L	行程 Travel	重量 Weight
HS250-300/420	300	35	150	200	—	—	—	—	35	420	6-φ18 鑽通	65	100	82
HS250-300/560	300	35	165	165	165	—	—	—	30	560	8-φ18 鑽通	222	240	90
HS250-420/560	420	35	165	165	165	—	—	—	30	560	8-φ18 鑽通	65	120	94
HS250-420/670	420	35	140	140	140	180	—	—	35	670	10-φ18 鑽通	87	230	110
HS250-420/750	420	25	140	140	140	140	140	—	25	750	12-φ18 鑽通	172	310	130
HS250-420/940	420	35	175	175	175	175	175	—	30	940	12-φ18 鑽通	362	500	155
HS250-420/1200	420	30	190	190	190	190	190	190	30	1200	14-φ18 鑽通	622	760	192

5090# 油壓滑台 (250H) Hydraulic Slide Units (250H)

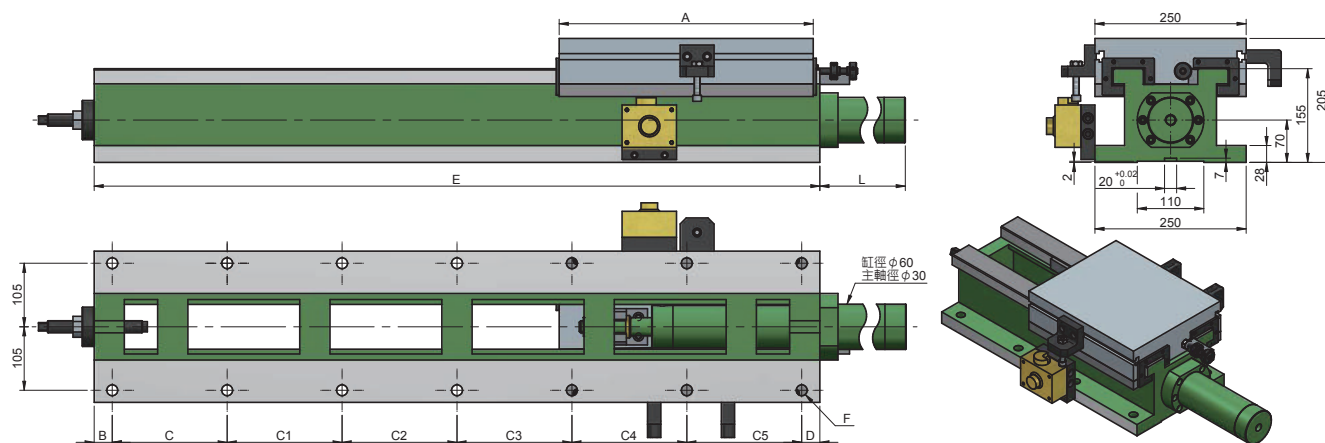

※可訂製滾珠螺桿伺服傳動 (BS系列)

單位 : mm

規格 Model	A	B	C	C1	C2	C3	C4	C5	D	E	F	L	行程 Travel	重量 Weight
HS250-300/420H	300	35	150	200	—	—	—	—	35	420	6-φ18 鑽通	75	100	92
HS250-300/560H	300	35	165	165	165	—	—	—	30	560	8-φ18 鑽通	224	240	100
HS250-420/560H	420	35	165	165	165	—	—	—	30	560	8-φ18 鑽通	75	120	108
HS250-420/670H	420	35	140	140	140	180	—	—	35	670	10-φ18 鑽通	75	230	130
HS250-420/750H	420	25	140	140	140	140	140	—	25	750	12-φ18 鑽通	179	310	148
HS250-420/940H	420	35	175	175	175	175	175	—	30	940	12-φ18 鑽通	368	500	178
HS250-420/1200H	420	30	190	190	190	190	190	190	30	1200	14-φ18 鑽通	628	760	215