

5090# 油壓滑台 (300) Hydraulic Slide Units (300)

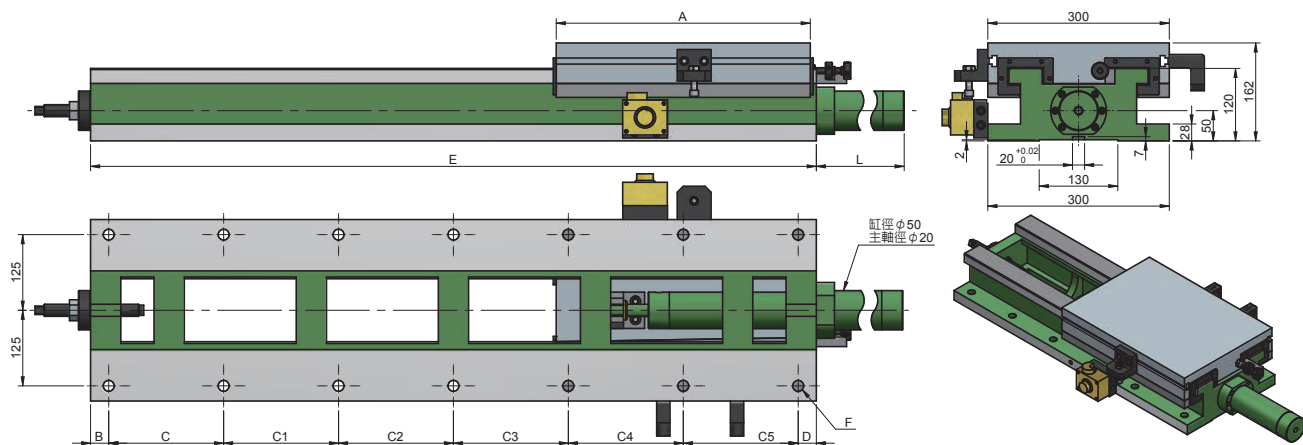

※可訂製滾珠螺桿伺服傳動 (BS系列)

單位：mm

規格 Model	A	B	C	C1	C2	C3	C4	C5	D	E	F	L	行程 Travel	重量 Weight
HS300-300/420	300	35	150	200	—	—	—	—	35	420	6-φ 18 鑽通	65	100	100
HS300-360/560	360	35	165	165	165	—	—	—	30	560	8-φ 18 鑽通	65	180	115
HS300-420/560	420	35	165	165	165	—	—	—	30	560	8-φ 18 鑽通	65	120	117
HS300-420/670	420	35	140	140	140	180	—	—	35	670	10-φ 18 鑽通	65	230	135
HS300-420/800	420	35	140	140	140	140	170	—	35	800	12-φ 18 鑽通	222	360	185
HS300-420/940	420	35	175	175	175	175	175	—	30	940	12-φ 18 鑽通	362	500	198
HS300-420/1200	420	30	190	190	190	190	190	190	30	1200	14-φ 18 鑽通	622	760	210

5090# 油壓滑台 (300H) Hydraulic Slide Units (300H)

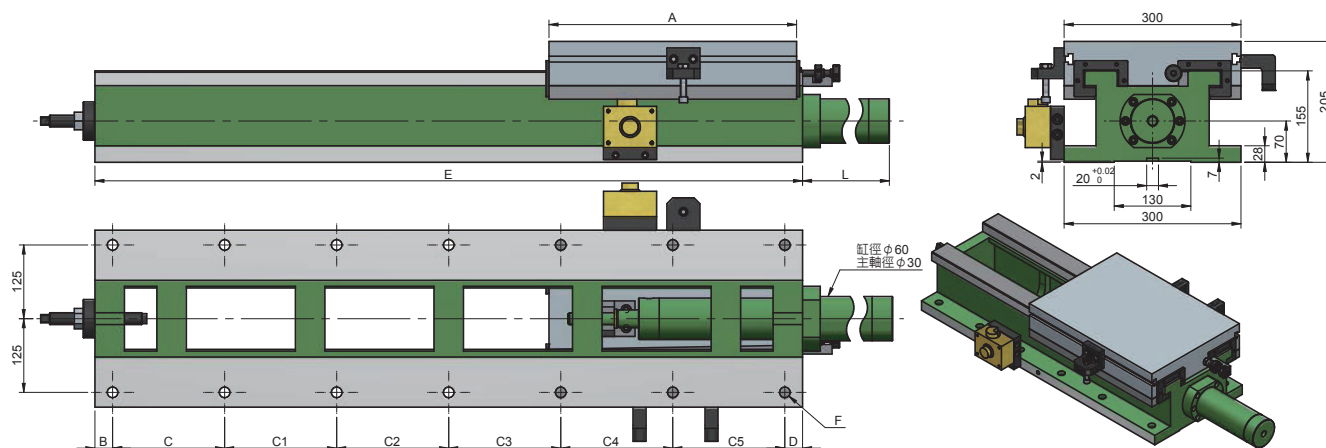

※可訂製滾珠螺桿伺服傳動 (BS系列)

單位：mm

規格 Model	A	B	C	C1	C2	C3	C4	C5	D	E	F	L	行程 Travel	重量 Weight
HS300-300/420H	300	35	150	200	—	—	—	—	35	420	6-φ 18 鑽通	75	100	120
HS300-360/560H	360	35	165	165	165	—	—	—	30	560	8-φ 18 鑽通	75	180	140
HS300-420/560H	420	35	165	165	165	—	—	—	30	560	8-φ 18 鑽通	75	120	144
HS300-420/670H	420	35	140	140	140	180	—	—	35	670	10-φ 18 鑽通	75	230	178
HS300-420/800H	420	35	140	140	140	140	170	—	35	800	12-φ 18 鑽通	224	360	195
HS300-420/940H	420	35	175	175	175	175	175	—	30	940	12-φ 18 鑽通	368	500	210
HS300-420/1200H	420	30	190	190	190	190	190	190	30	1200	14-φ 18 鑽通	628	760	246