

5029# S55 搪銑主軸頭 Boring & Milling Head Unit

規格	Model	S55	S55H
主軸	Spindle	NT40 or MT4	
最高轉速	Max. RPM	2000	6000
軸承	Bearing	32011 / 6011Z 32010 / 6010Z	7011×2 7010×2
真圓度	Roundness	Within 0.003mm 內	
最大動力	Max. Power	Within 3 HP 內	
溫升	Rising Temperature	Within 20°C 內	

★出廠附精度檢驗表

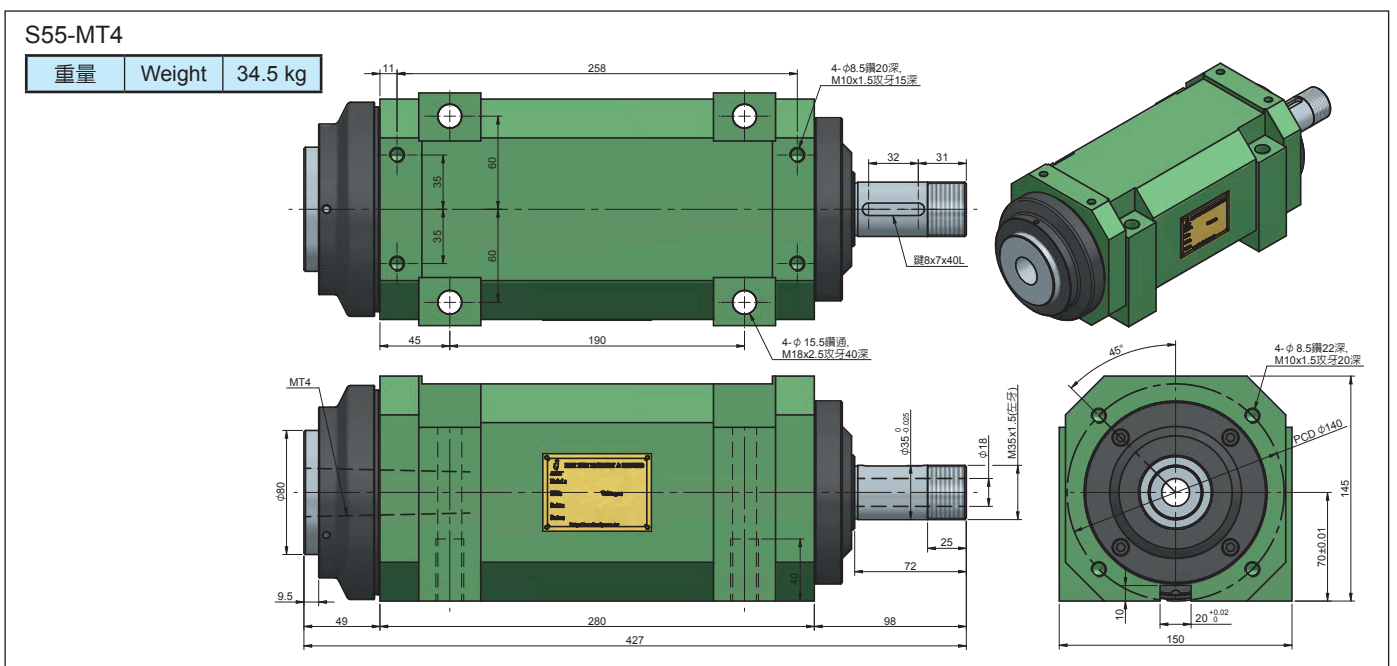
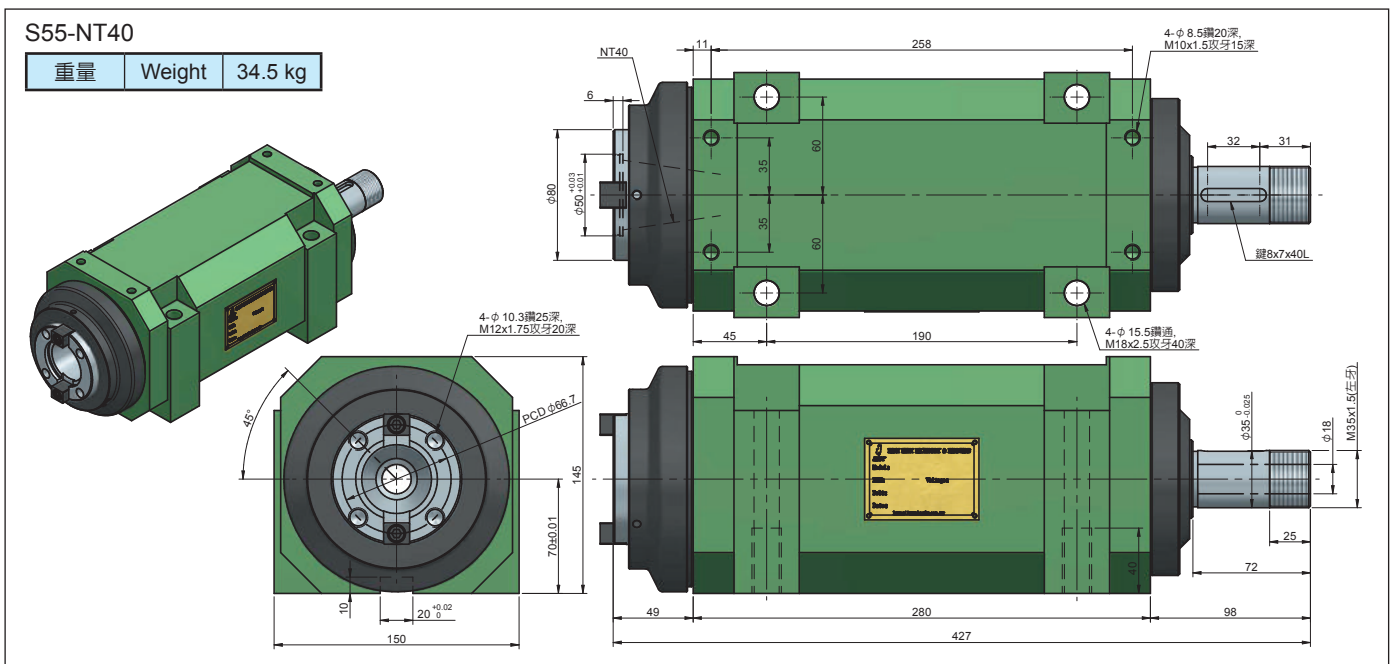

5029# S55 搪銑主軸頭 Boring & Milling Head Unit

S55-NT40-MF
S55-MT4-MF

重量	Weight	75 kg
----	--------	-------

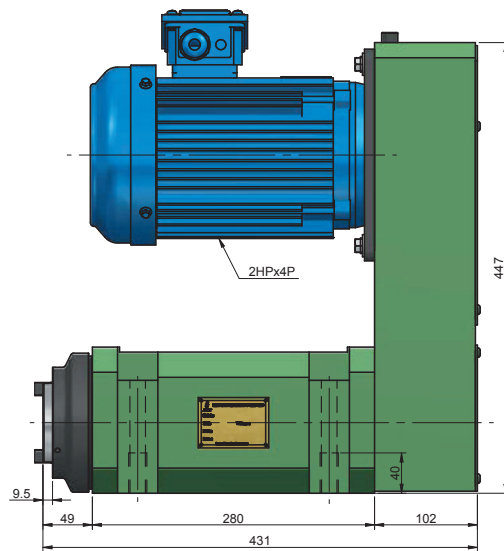
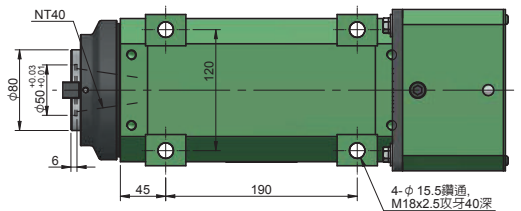
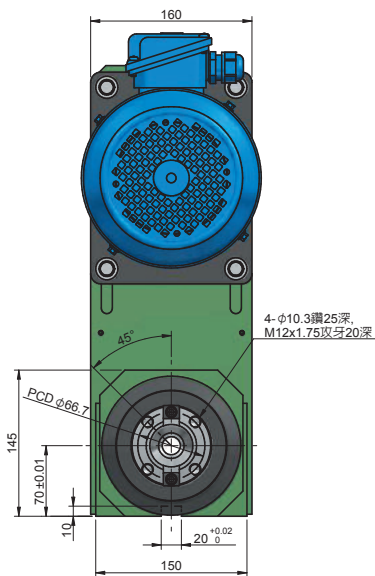
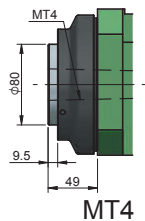
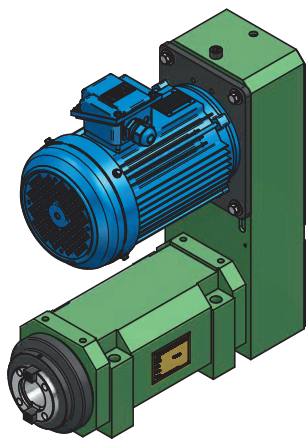

S55-NT40-MB
S55-MT4-MB

重量	Weight	75 kg
----	--------	-------

