

5057# SC80-BT50 搪銑主軸頭 / 氣動打刀缸

Boring / Milling Head Unit / with Unclamping Cylinder

規格	Model	SC80-BT50	SC80H-BT50
主軸	Spindle	BT50	
最高轉速	Max. RPM	1200	3000
軸承	Bearing	32216×2 6216Z×2	7216×4
真圓度	Roundness	Within 0.003mm內	
最大動力	Max. Power	Within 7.5 HP 內	
溫升	Rising Temperature	Within 20°C 內	

SC80-BT50-MF

重量	Weight	kg
----	--------	----

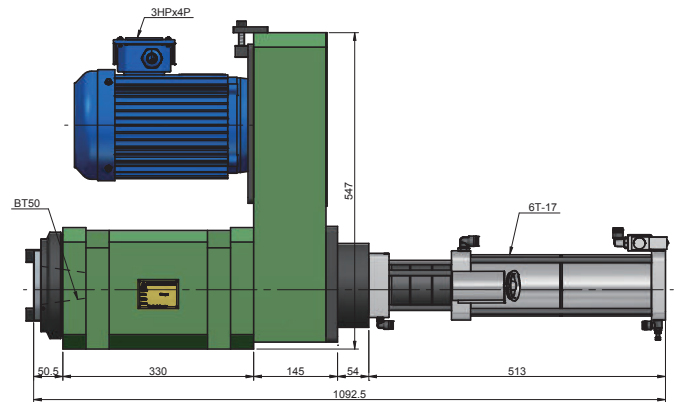
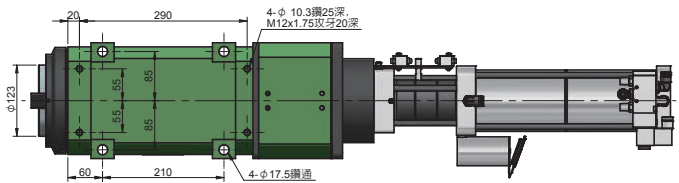
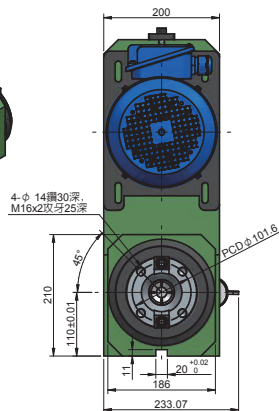
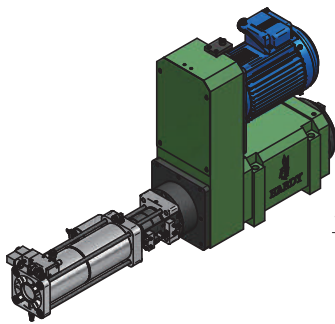

SC80-BT50-MB

重量	Weight	kg
----	--------	----

