

5069# SD09-120 油壓鑽孔/搪銑動力頭 Drilling/Milling Spindle Head-Hydraulic Type

SD09-NT30-MF
SD09-HSK50-MF

重量	Weight	94 kg
----	--------	-------

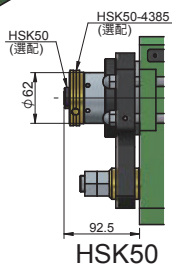
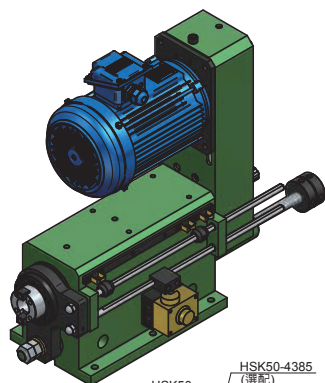

HSK50

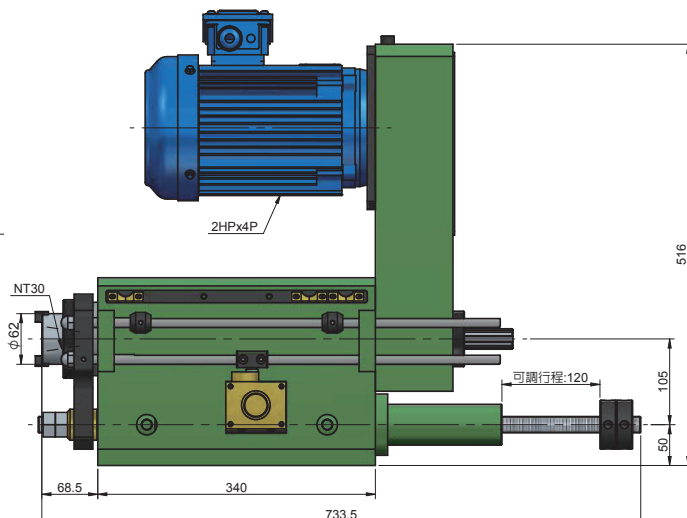
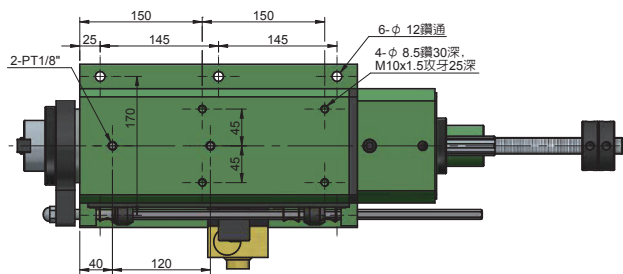
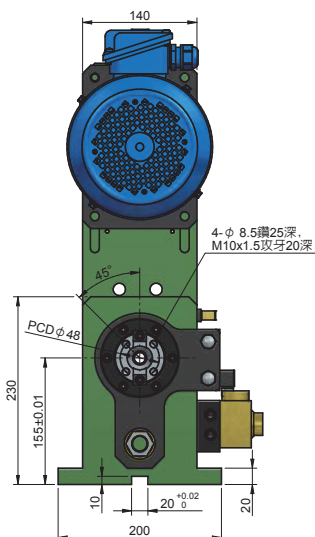

SD09-NT30-MB
SD09-HSK50-MB

重量	Weight	94 kg
----	--------	-------

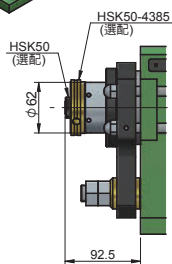
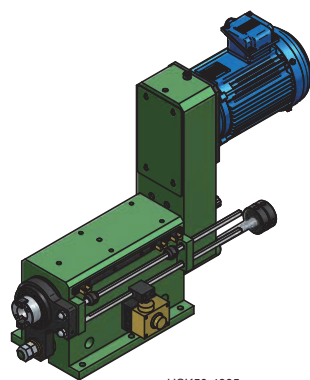

HSK50

