

## 5065# SD3-60/80 鑽孔主軸頭 Drilling Head Units

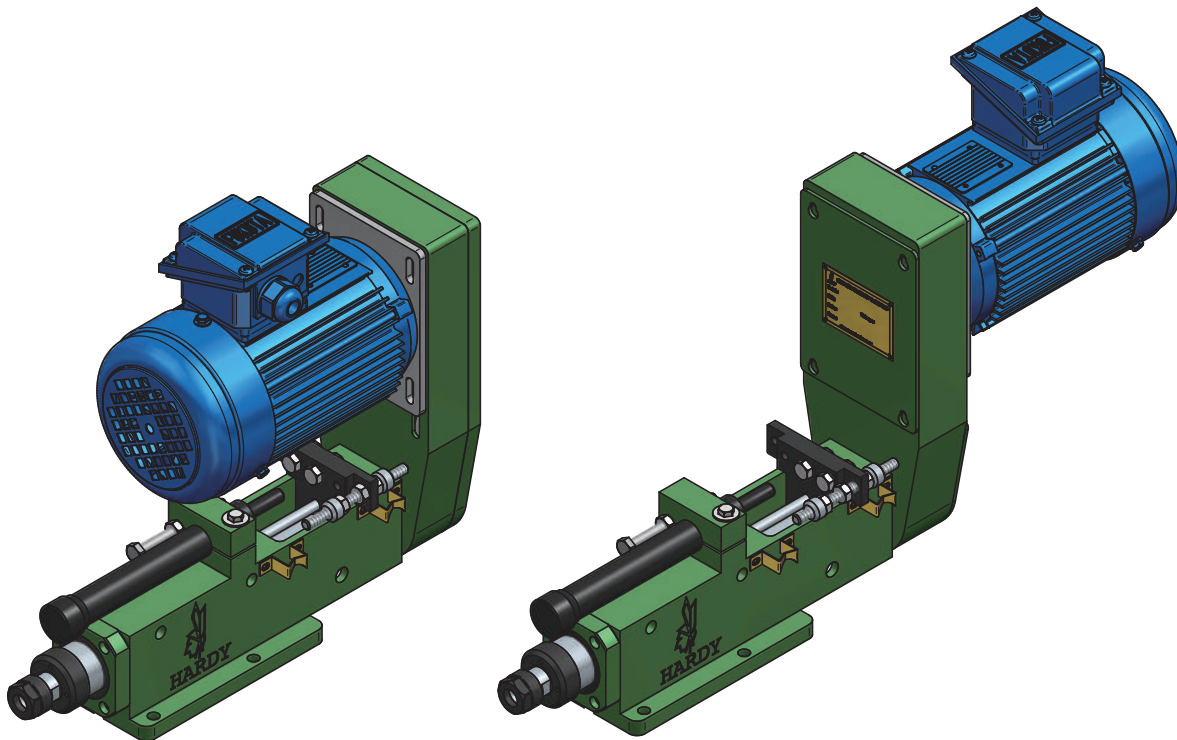

穩速器可選配美製 - 白馬牌

規格	Model	SD3-60	SD3-80	SD3A-55	SD3A-75
鑽孔能力	Drilling Capacity (S45C)	φ 6 mm			
最大行程	Max. Stroke	60mm	80mm	55mm	75mm
最高轉速	Max. RPM	10000 RPM			
推進壓力	Propel Pressure	油壓 (H) 10~15 kg/cm <sup>2</sup>		空壓 (A) 4~8 kg/cm <sup>2</sup>	
油缸面積	Cylinder Diameter	前進 (F) 12.6 cm <sup>2</sup> 後退 (B) 7.1 cm <sup>2</sup>			
馬力	Horsepower, 3 Phase	1/2 HP, 220V/380V, 三相			
傳動皮帶	Transmission Belt	5J - 200			
主軸軸承	Spindle Bearing	6002ZZ×4			
皮帶輪軸承	Pulley Bearing	6002ZZ×3			
前蓋油封	Front Cover Seal	TC22-30-7×1 AP-326×2		TC22-30-7×1 UH40×2	
活塞O型環	Piston O-ring	AG-45×2, AG-40×2		AG-45×2, AG-40×1	
前蓋O型環	Front Cover O-ring	TC30-40-7×1			
後蓋油封	Back Cover Seal	AG-45×2, UH30×1		AG-45×1, AG-30×2	
後蓋O型環	Back Cover O-ring	AG-45×1, AG-30×2			

Roundness: ≤ 0.003mm





**HARDY**

## 5065# SD3-80 鑽孔主軸頭 Drilling Head Units

SD3-80-ER16-FL(左向) / FR(右向)  
SD3-80-JT1-FL(左向) / FR(右向)  
SD3-80-JT2-FL(左向) / FR(右向)

重量	Weight	21 kg
----	--------	-------

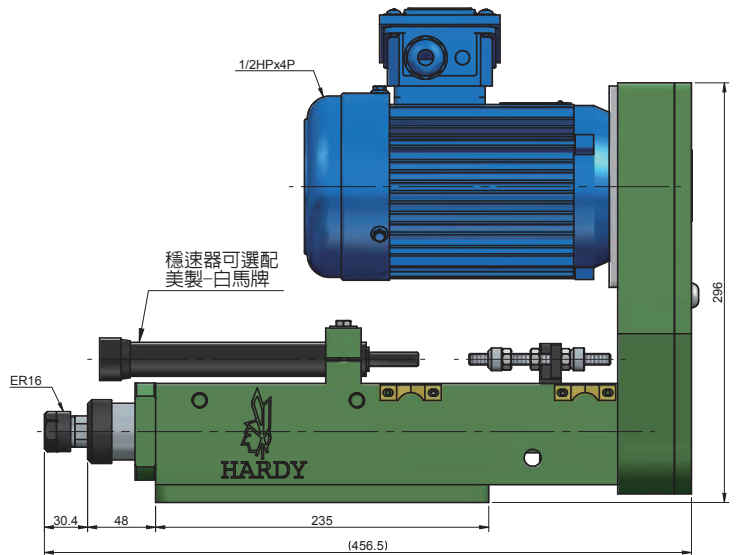
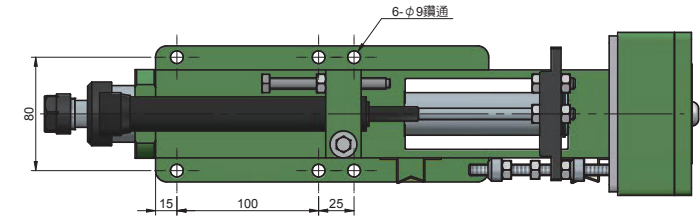
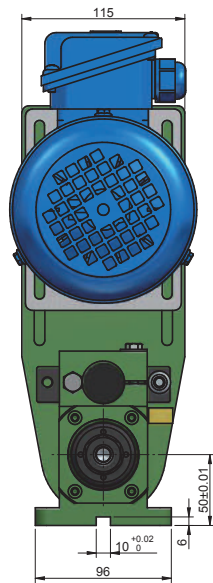
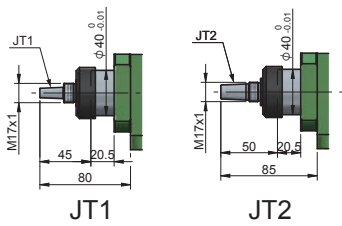
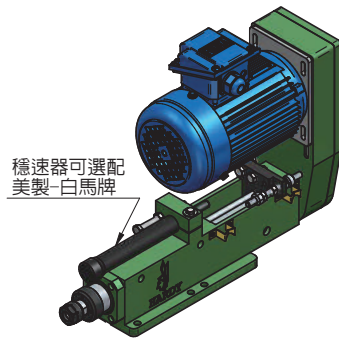

SD3-80-ER16-BL(左向) / BR(右向)  
SD3-80-JT1-BL(左向) / BR(右向)  
SD3-80-JT2-BL(左向) / BR(右向)

重量	Weight	21 kg
----	--------	-------

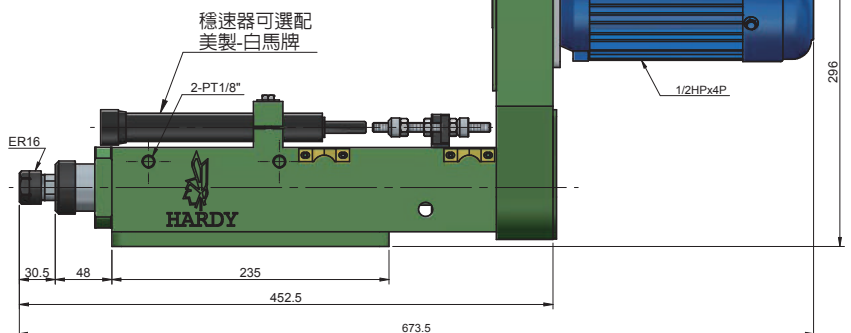
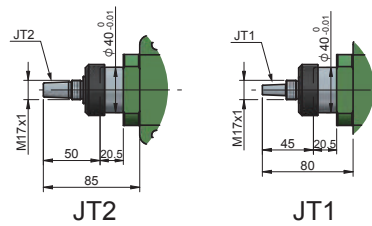
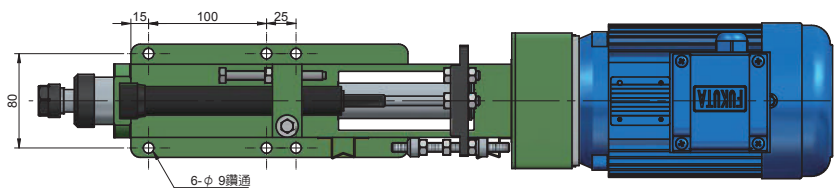
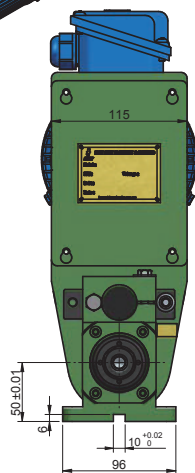
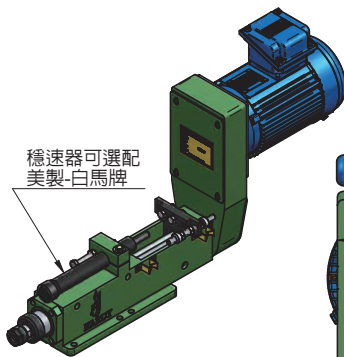



## 5065# SD3A-55 鑽孔主軸頭-空壓 Drilling Head Units-Pneumatic

空壓Pneumatic SD3A-55-ER16-FL(左向) / FR(右向)  
 空壓Pneumatic SD3A-55-JT1-FL(左向) / FR(右向)  
 空壓Pneumatic SD3A-55-JT2-FL(左向) / FR(右向)  
 空壓Pneumatic SD3A-55-KH14E-FL(左向) / FR(右向)

重量	Weight	21 kg
----	--------	-------

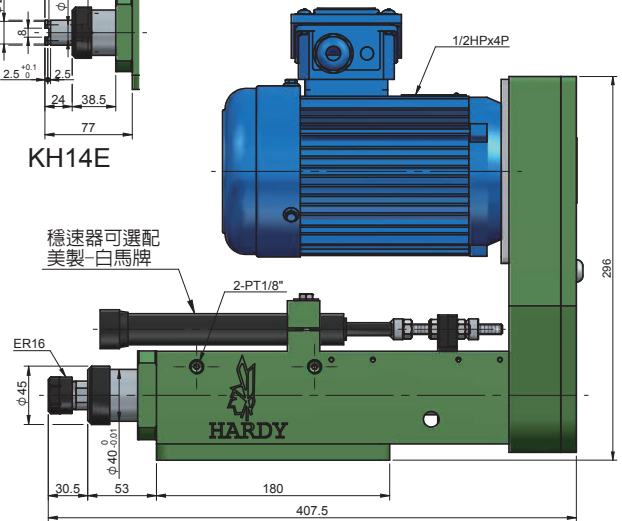
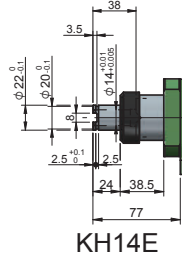
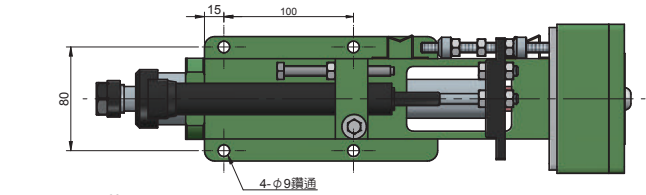
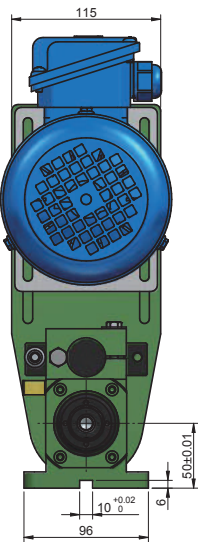
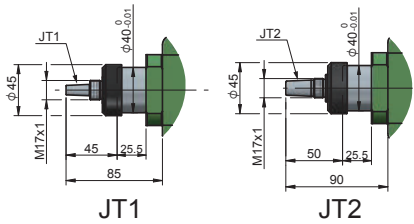
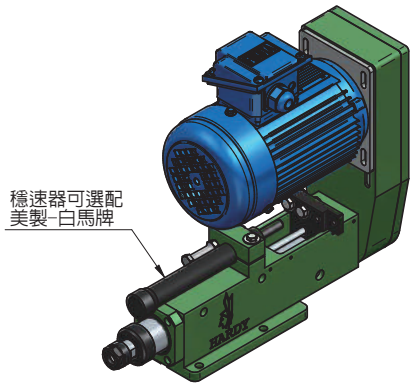

空壓Pneumatic SD3A-55-ER16-BL(左向) / BR(右向)  
 空壓Pneumatic SD3A-55-JT1-BL(左向) / BR(右向)  
 空壓Pneumatic SD3A-55-JT2-BL(左向) / BR(右向)  
 空壓Pneumatic SD3A-55-KH14E-BL(左向) / BR(右向)

重量	Weight	21 kg
----	--------	-------

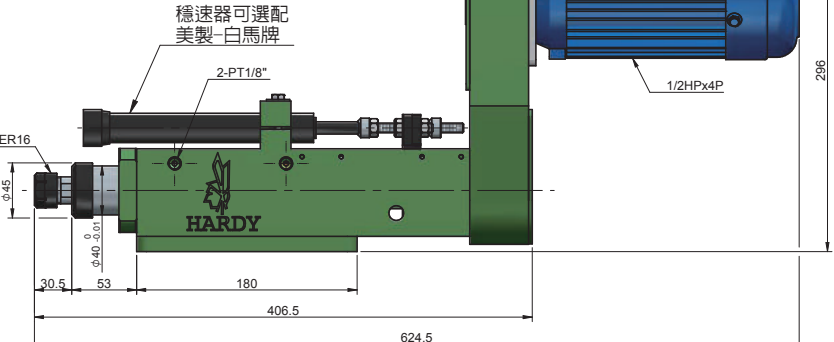
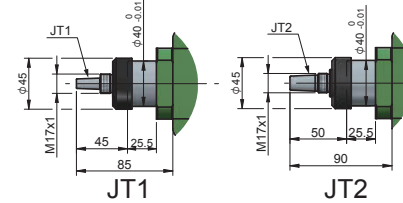
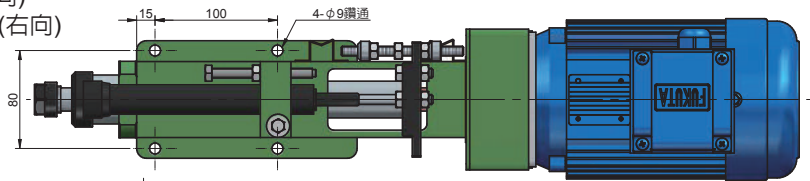
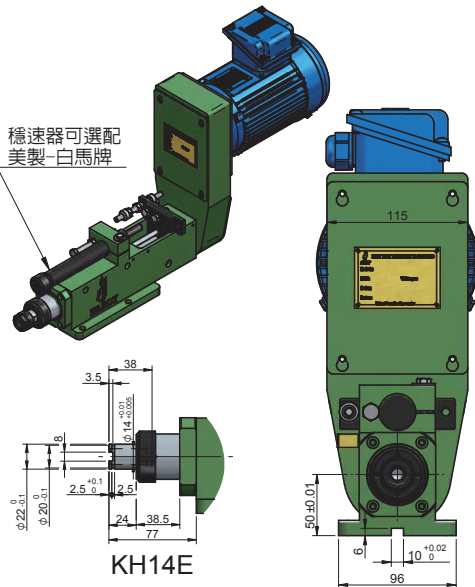



**HARDY**

## 5065# SD3A-75 鑽孔主軸頭-空壓 Drilling Head Units-Pneumatic

空壓Pneumatic SD3A-75-ER16-FL(左向) / FR(右向)  
 空壓Pneumatic SD3A-75-JT1-FL(左向) / FR(右向)  
 空壓Pneumatic SD3A-75-JT2-FL(左向) / FR(右向)

重量	Weight	21 kg
----	--------	-------

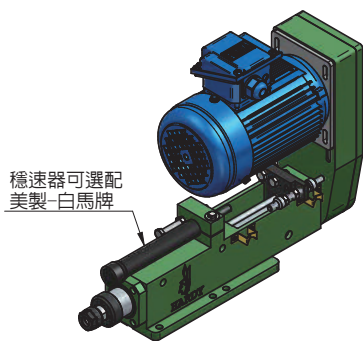

穩速器可選配  
美製-白馬牌

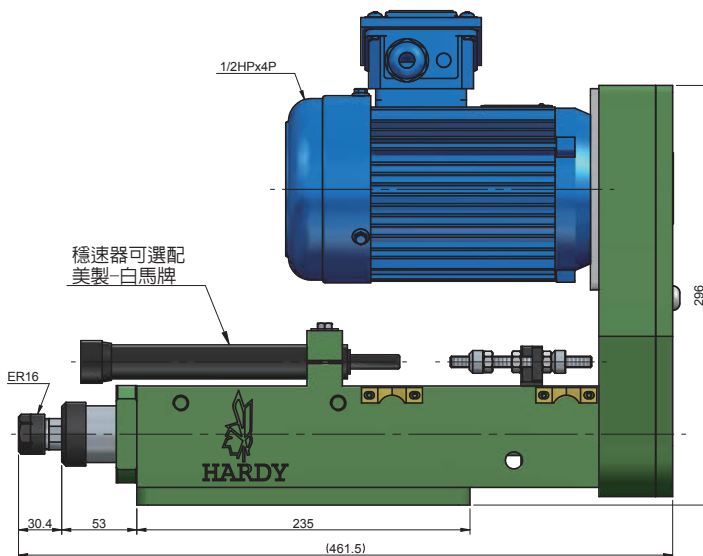
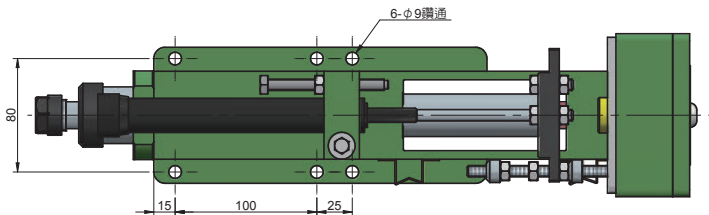
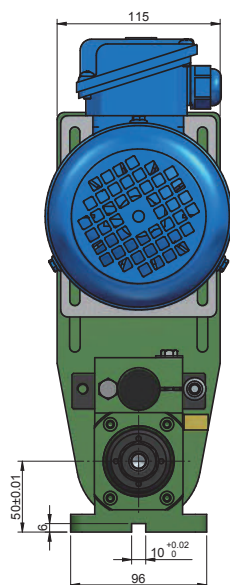
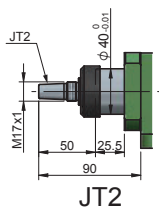
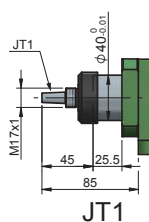

空壓Pneumatic SD3A-75-ER16-BL(左向) / BR(右向)  
 空壓Pneumatic SD3A-75-JT1-BL(左向) / BR(右向)  
 空壓Pneumatic SD3A-75-JT2-BL(左向) / BR(右向)

重量	Weight	21 kg
----	--------	-------

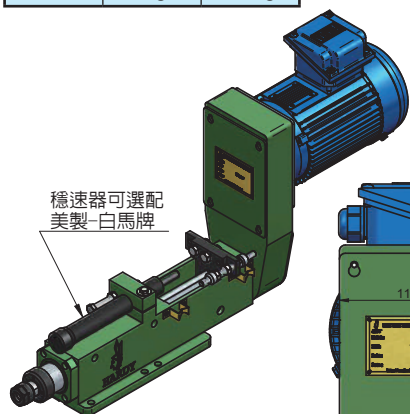

穩速器可選配  
美製-白馬牌

