

5014# SFHD11-120 水車油壓鑽孔動力頭 Drilling Spindle Head-Hydraulic /Flange Type

規格	Model	SFHD11	SFHD11H
鑽孔能力	Drilling Capacity(S45C)	φ 35	
最大行程	Max. Stroke	120mm	
最高轉速	Max. RPM	1800	4000
馬力	Horsepower	3HP×4P	
主軸皮帶輪	Spindle Pulley	8M-64T	
主軸軸承	Spindle Bearing	6210ZZ×2 / 30210×2	7210×4
皮帶輪軸承	Pulley Bearing	6015ZZ×2	
前蓋油封	Front Cover Seal	TC110-130-13×1	
主軸油封	Spindle Seal	TC70-90-12×1	
活塞O型環	Piston O-ring	P110×2	
防水蓋O型環	Front Cover O-ring	G85×1 / G110×1	
推進壓力	Propel Pressure	油壓(H)30~40kg/cm ²	
油缸面積	Cylinder Diameter	14.7cm ² (缸徑φ 50 ; 心軸φ 25)	

Roundness: ≤ 0.003mm

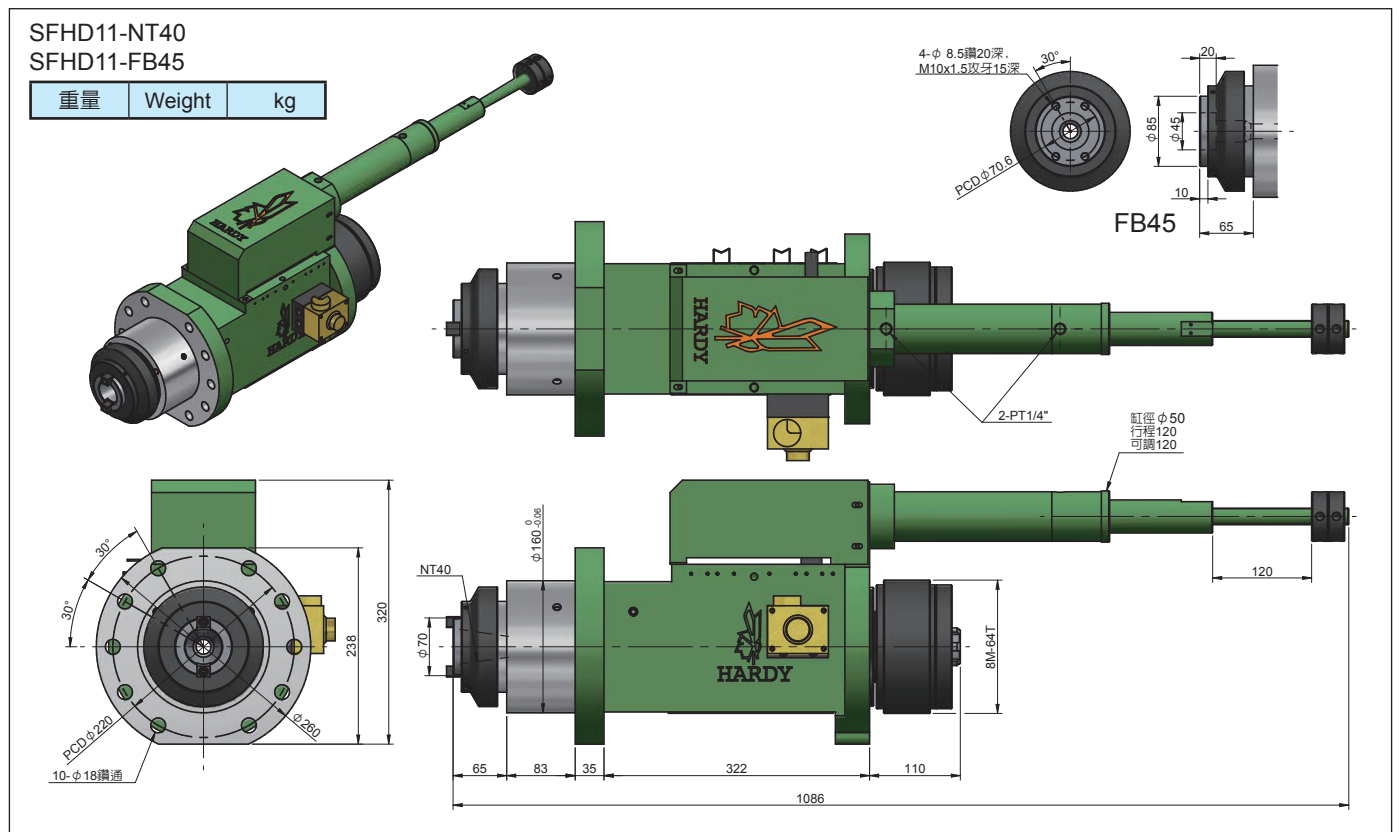

5014# SFHD11-120 水車油壓鑽孔動力頭 Drilling Spindle Head-Hydraulic /Flange Type

