

5016# SFHD15-150 水車油壓鑽孔動力頭 Drilling Spindle Head-Hydraulic / Flange Type

規格	Model	SFHD15	SFHD15H
鑽孔能力	Drilling Capacity(S45C)	φ 50	
最大行程	Max. Stroke	150mm	
最高轉速	Max. RPM	1600	4000
馬力	Horsepower	5HP×4P	
主軸皮帶輪	Spindle Pulley	8M-62T, φ 156.5×J×25	
主軸軸承	Spindle Bearing	6014Z×1 / 6012Z×1 32014×1 / 32012×1	7014×2 7012×2
皮帶輪軸承	Pulley Bearing	6213ZZ×2	
前蓋油封	Front Cover Seal	TC150-180-14×1	
主軸油封	Spindle Seal	TC90-100-12×1	
活塞O型環	Piston O-ring	P150×2	
防水蓋O型環	Front Cover O-ring	G120×1 / G150×1	
推進壓力	Propel Pressure	油壓(H)30~40kg/cm ²	
油缸面積	Cylinder Diameter	21.2cm ² (缸徑 φ 60 ; 心軸 φ 30)	

Roundness: ≤ 0.003mm

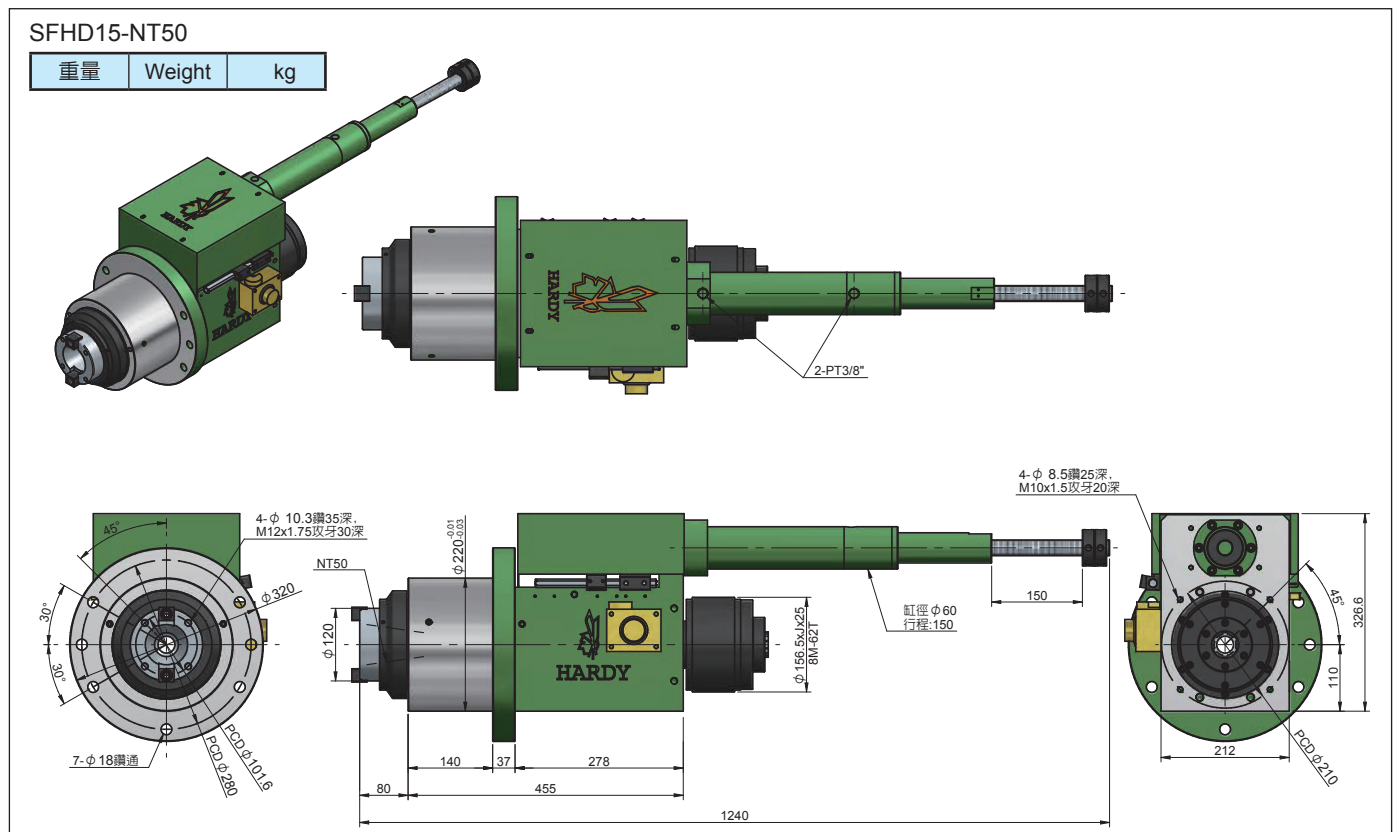

5016# SFHD15-150 水車油壓鑽孔動力頭 Drilling Spindle Head-Hydraulic /Flange Type

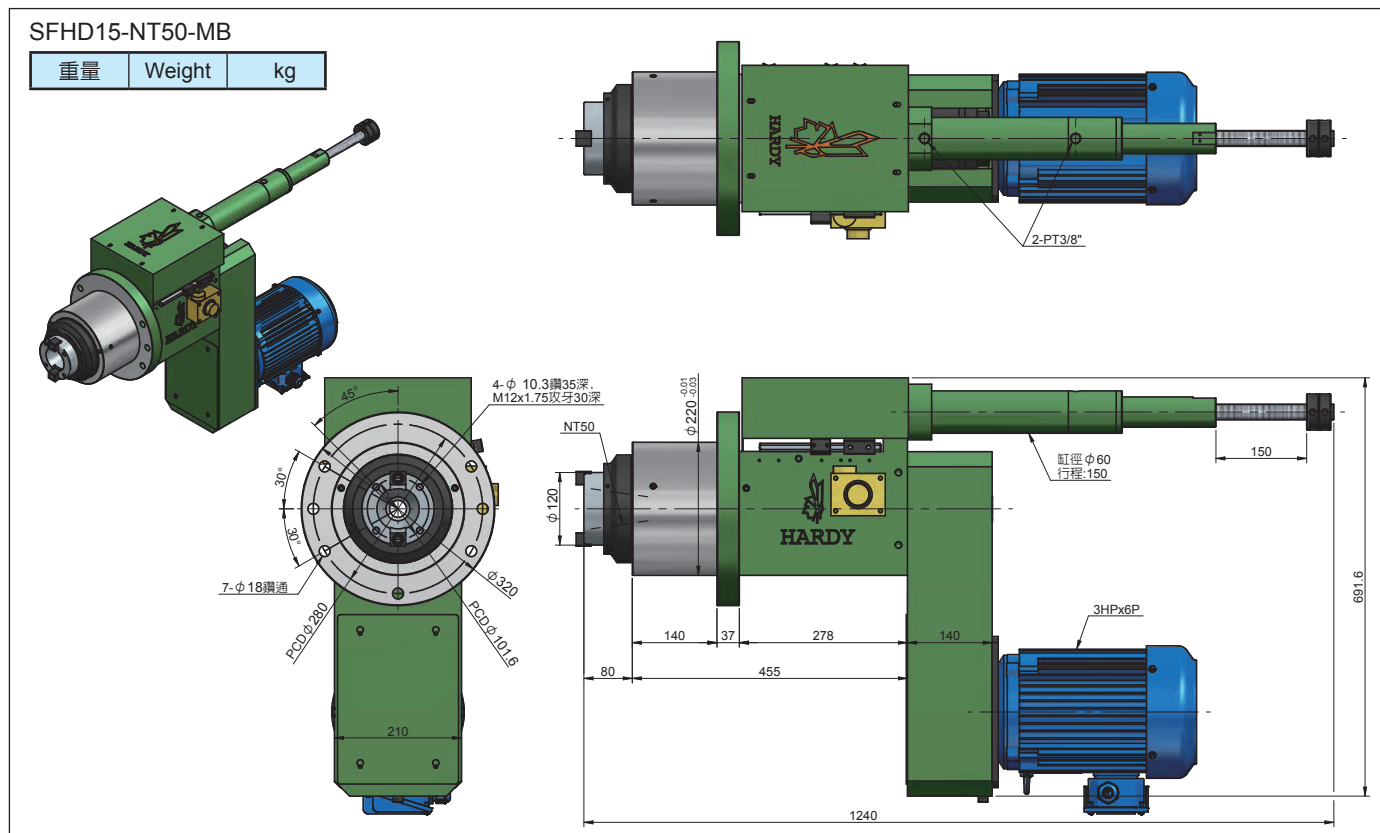

可接受特殊規格動力頭訂製
We accept Special Spindle Unit Order

