

5007# SFSD06-100 水車伺服鑽孔/攻牙動力頭 Drilling/Tapping Spindle Head-Servo /Flange Type

規格	Model	SFSD06	SFSD06H
鑽孔能力	Drilling Capacity(S45C)	φ 16	
最大行程	Max. Stroke	100mm	
最高轉速	Max. RPM	3500	10000
馬力	Horsepower	1HP×4P	
主軸皮帶輪	Spindle Pulley	5M-50T / φ 78.5×J×15	
主軸軸承	Spindle Bearing	6006Z×1 / 6005Z×1 32006×1 / 32005×1	7006×2 7005×2
皮帶輪軸承	Pulley Bearing	6908ZZ×2	
螺桿軸承座軸承	Bearing Of Ballscrew Bearing Block	7203×2	
螺桿軸承座油封	Seal Of Ballscrew Bearing Block	TC24-38-8×1 / TC20-40-8×1	
前蓋油封	Front Cover Seal	TC70-90-12×1	
前蓋O型環	Front Cover O-ring	G70×1 / G40(G48-HSK40)×1	
主軸油封	Spindle Seal	TC45-60-7×1	
活塞O型環	Piston O-ring	P70×2	
滾珠螺桿	Ball screw	φ 20×5×C5	

Roundness: $\leq 0.003\text{mm}$

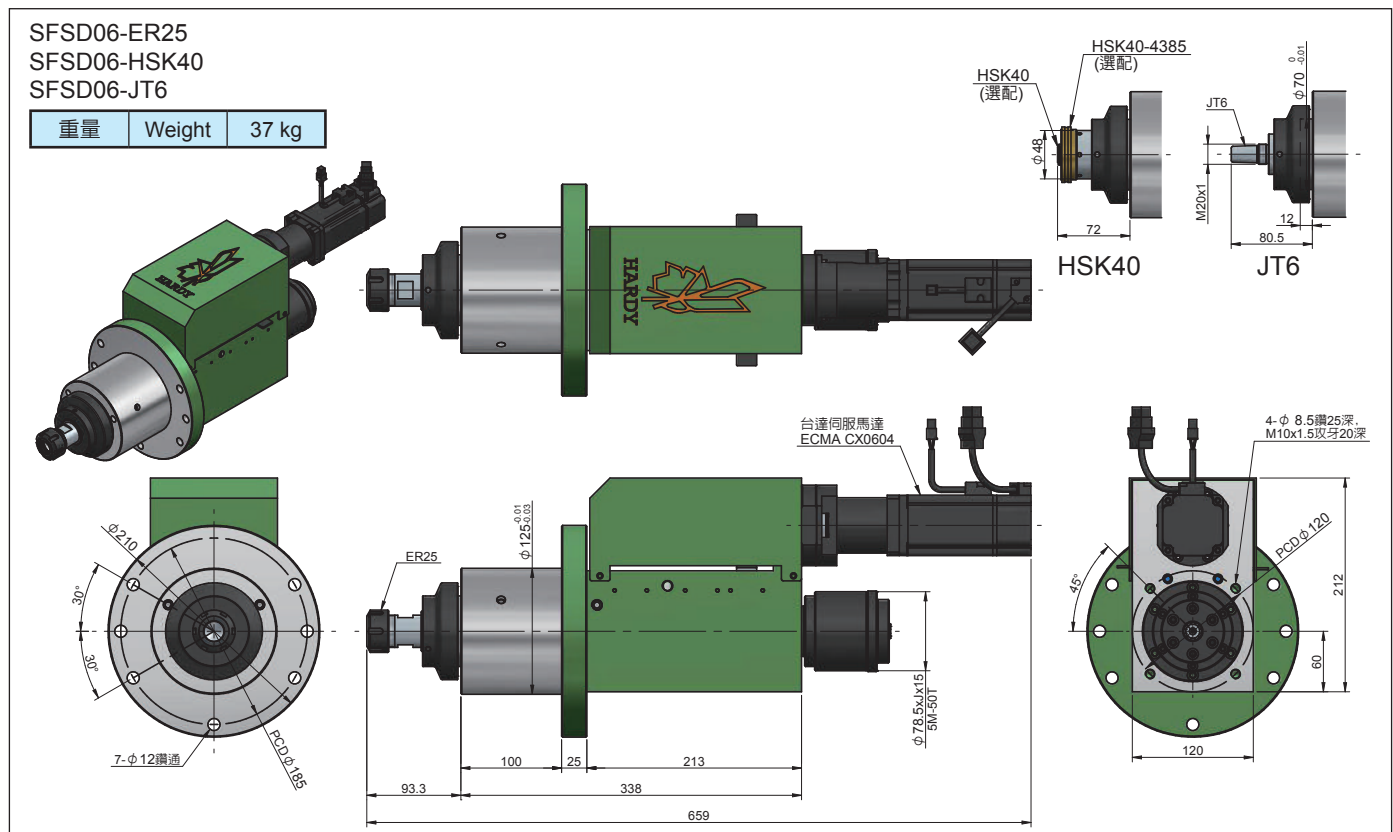

5007# SFSD06-100 水車伺服鑽孔/攻牙動力頭 Drilling/Tapping Spindle Head-Servo /Flange Type

SFSD06-ER25-MB
SFSD06-HSK40-MB
SFSD06-JT6-MB

重量	Weight	57 kg
----	--------	-------

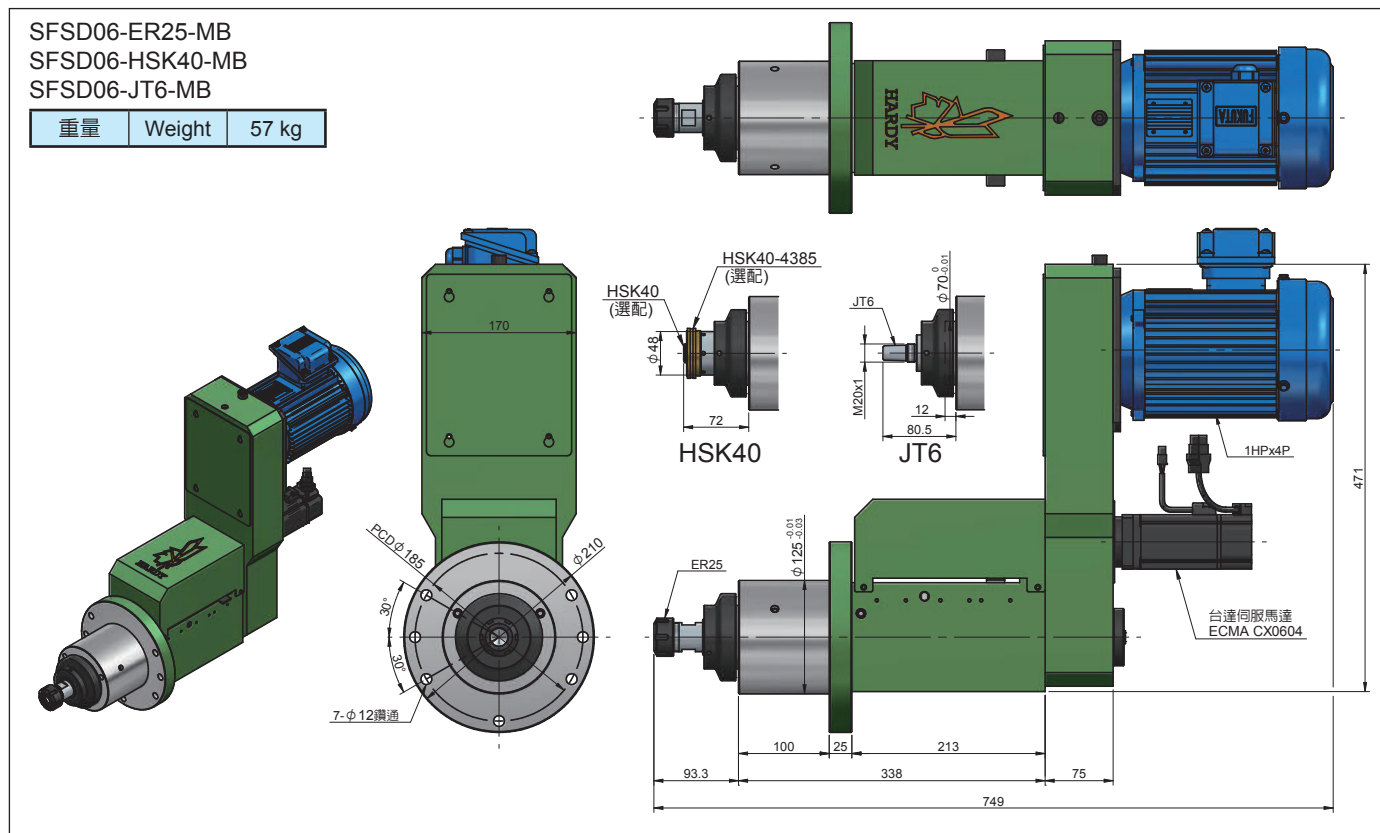

可接受特殊規格動力頭訂製
We accept Special Spindle Unit Order

