

5008# SFSD09-120 水車伺服鑽孔/攻牙動力頭 Drilling/Tapping Spindle Head-Servo /Flange Type

規格	Model	SFSD09	SFSD09H
鑽孔能力	Drilling Capacity(S45C)	φ25	
最大行程	Max. Stroke	120mm	
最高轉速	Max. RPM	3000	8000
馬力	Horsepower	2HP×4P	
主軸皮帶輪	Spindle Pulley	5M-66T, φ 102.3×J×20	
主軸軸承	Spindle Bearing	6007Z×1 / 6006Z×1 32007×1 / 32006×1	7007×2 7006×2
皮帶輪軸承	Pulley Bearing	6010ZZ×2	
螺桿軸承座軸承	Bearing Of Ballscrew Bearing Block	7203×2	
螺桿軸承座油封	Seal Of Ballscrew Bearing Block	TC24-38-8×1 / TC20-40-8×1	
前蓋油封	Front Cover Seal	TC90-110-12×1	
前蓋O型環	Front Cover O-ring	G90×1 / G62×1	
主軸油封	Spindle Seal	TC50-65-8×1	
活塞O型環	Piston O-ring	P90×2	
滾珠螺桿	Ball Screw	φ 20×5×C5	

Roundness: ≤ 0.003mm

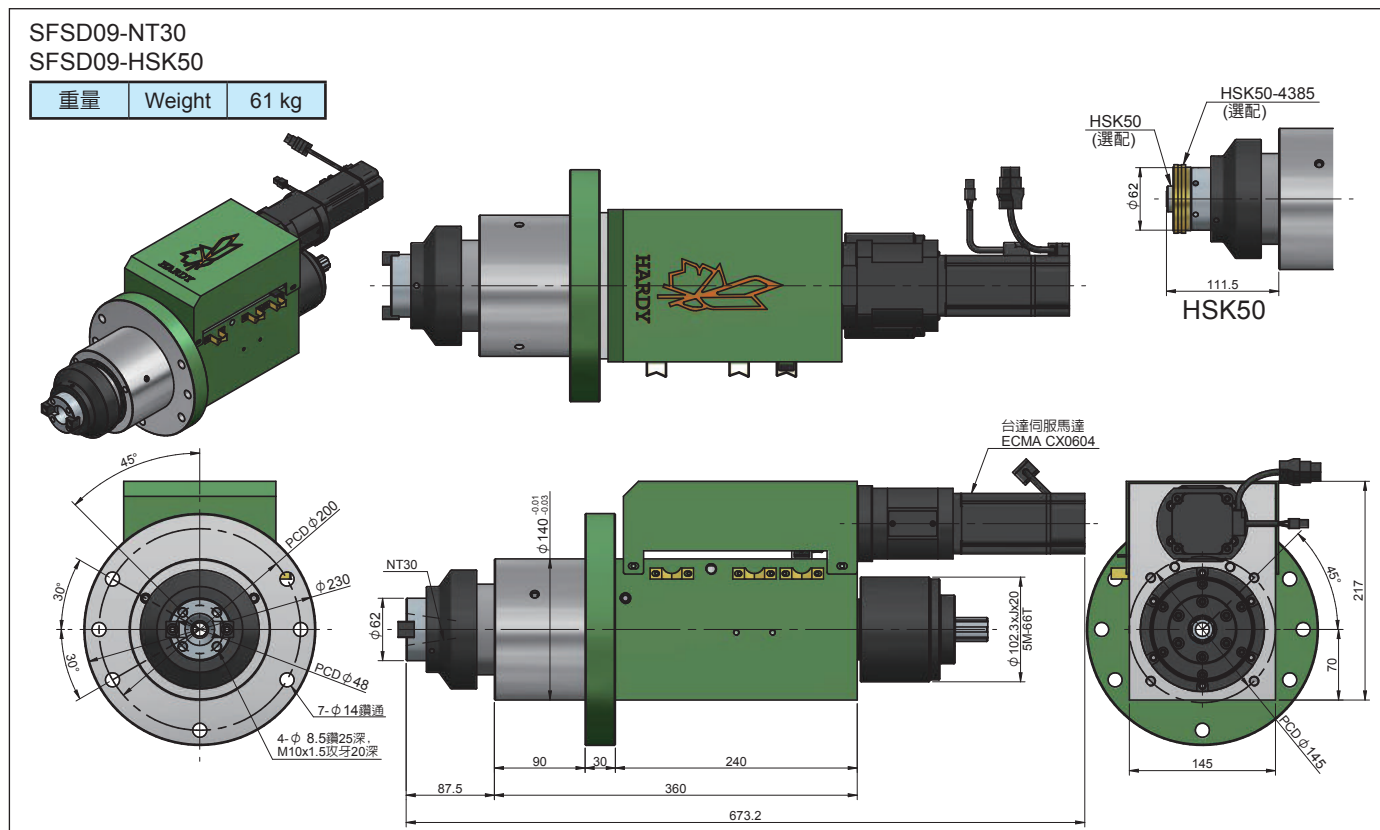

5008# SFSD09-120 水車伺服鑽孔/攻牙動力頭 Drilling/Tapping Spindle Head-Servo /Flange Type

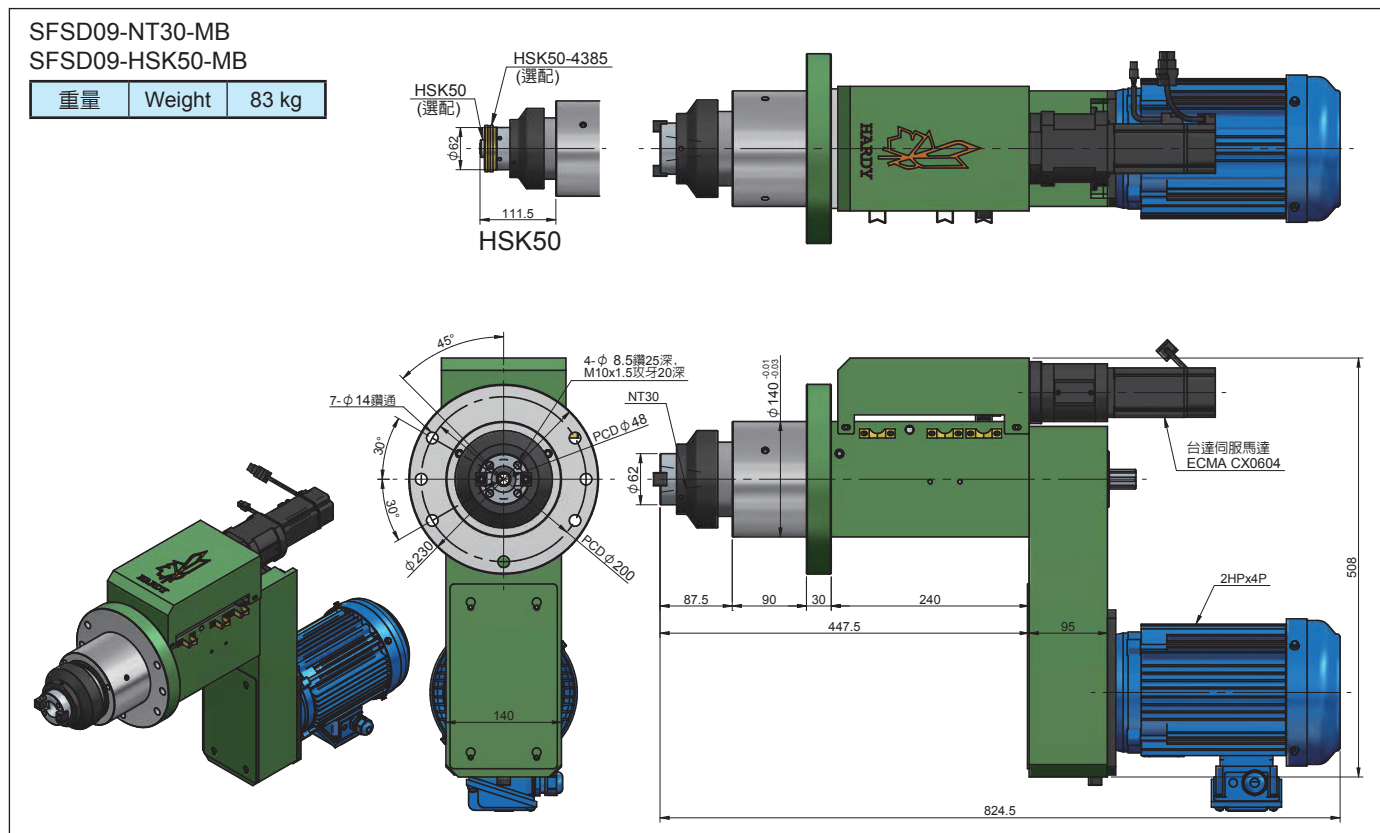

可接受特殊規格動力頭訂製
We accept Special Spindle Unit Order

