

5010# SFSD12-150 水車伺服鑽孔/攻牙動力頭 Drilling/Tapping Spindle Head-Servo /Flange Type

規格	Model	SFSD12	SFSD12H
鑽孔能力	Drilling Capacity(S45C)	φ 35	
最大行程	Max. Stroke	150mm	
最高轉速	Max. RPM	2000	6000
馬力	Horsepower	3HP×4P	
主軸皮帶輪	Spindle Pulley	8M-54T, φ 133.6×J×25	
主軸軸承	Spindle Bearing	6011Z×1 / 6009Z×1 32011×1 / 32009×1	7011×2 7009×2
皮帶輪軸承	Pulley Bearing	6211ZZ×2	
螺桿軸承座軸承	Bearing Of Ballscrew Bearing Block	7204×2	
螺桿軸承座油封	Seal Of Ballscrew Bearing Block	TC26-42-8×1 / TC24-42-8×1	
前蓋油封	Front Cover Seal	TC120-145-12×1	
前蓋O型環	Front Cover O-ring	G120×1 / G85×1	
主軸油封	Spindle Seal	TC75-90-12×1	
活塞O型環	Piston O-ring	P120×2	
滾珠螺桿	Ball Screw	φ 25×5×C5	

Roundness: ≤ 0.003mm

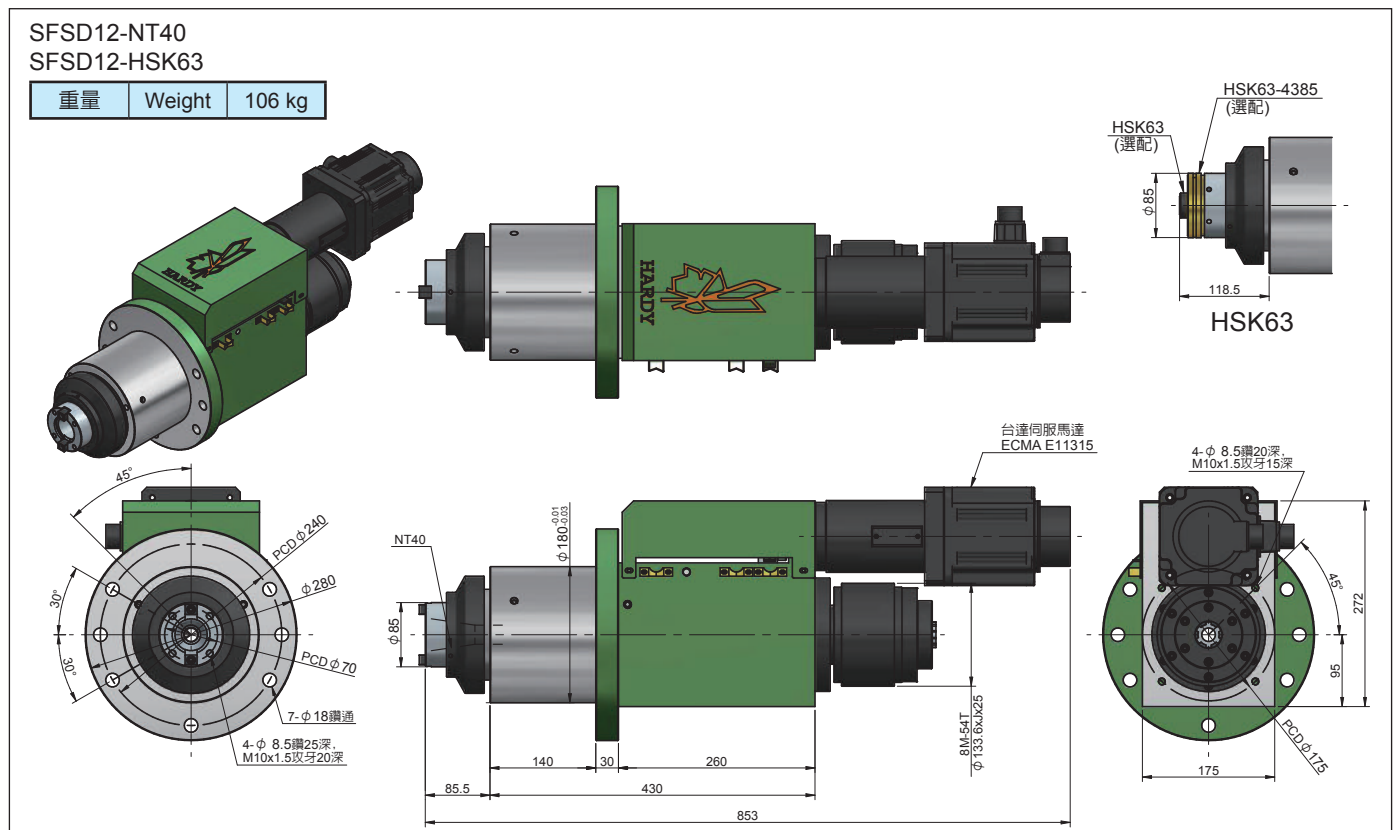

5010# SFSD12-150 水車伺服鑽孔/攻牙動力頭 Drilling/Tapping Spindle Head-Servo /Flange Type

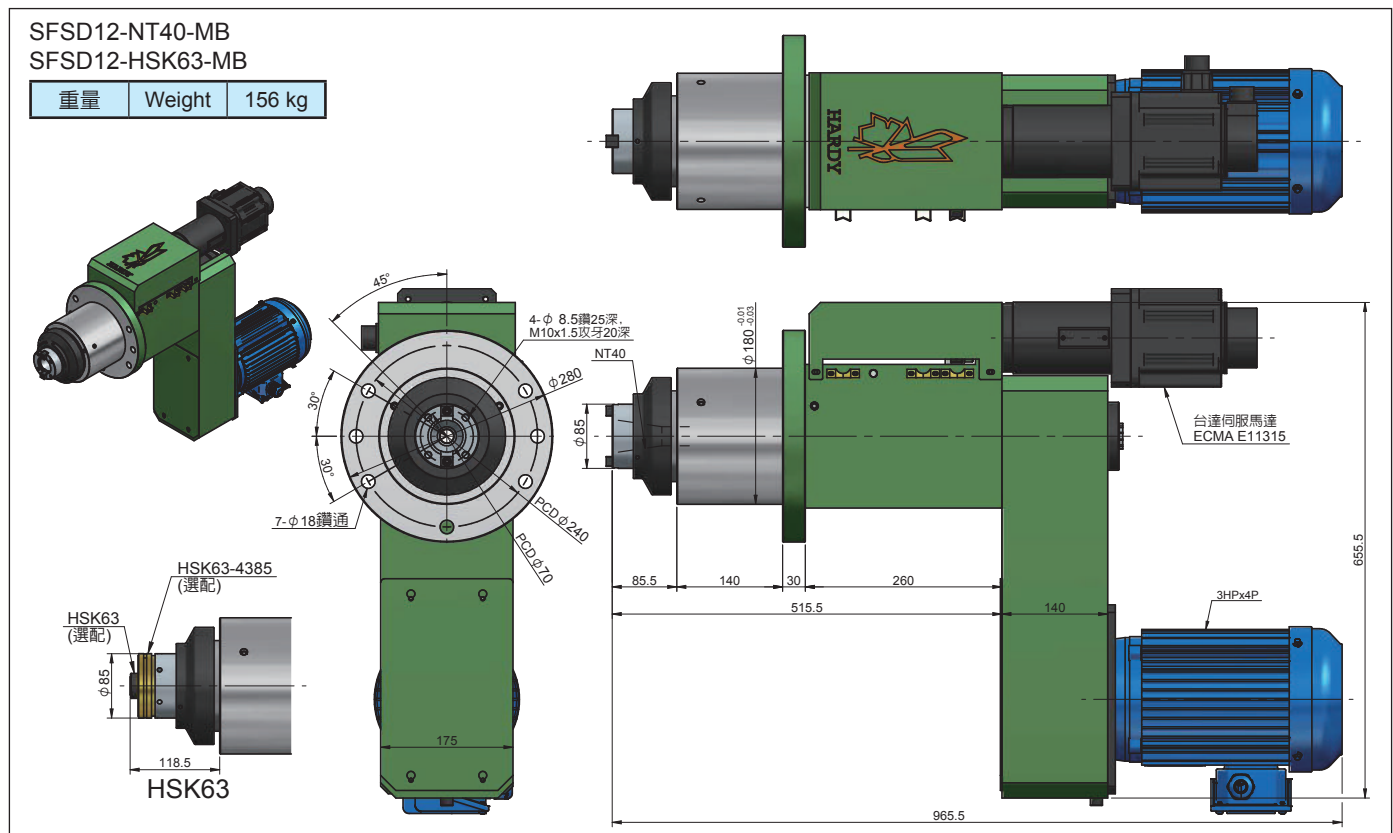

可接受特殊規格動力頭訂製
We accept Special Spindle Unit Order

