

## 5011# SFSD15-150 水車伺服鑽孔/攻牙動力頭 Drilling/Tapping Spindle Head-Servo /Flange Type

規格	Model	SFSD15	SFSD15H
鑽孔能力	Drilling Capacity(S45C)	φ50	
最大行程	Max. Stroke	150mm	
最高轉速	Max. RPM	1600	4000
馬力	Horsepower	5HP×4P	
主軸皮帶輪	Spindle Pulley	8M-62T, φ156.5×J×25	
主軸軸承	Spindle Bearing	6014Z×1 / 6012Z×1 32014×1 / 32012×1	7014×2 7012×2
皮帶輪軸承	Pulley Bearing	6213ZZ×2	
螺桿軸承座軸承	Bearing Of Ballscrew Bearing Block	7205×2	
螺桿軸承座油封	Seal Of Ballscrew Bearing Block	TC30-50-10×2	
前蓋油封	Front Cover Seal	TC150-180-14×1	
前蓋O型環	Front Cover O-ring	G120×1 / G150×1	
主軸油封	Spindle Seal	TC90-110-12×1	
活塞O型環	Piston O-ring	P150×2	
滾珠螺桿	Ball Screw	φ32×5×C5	

Roundness: ≤ 0.003mm

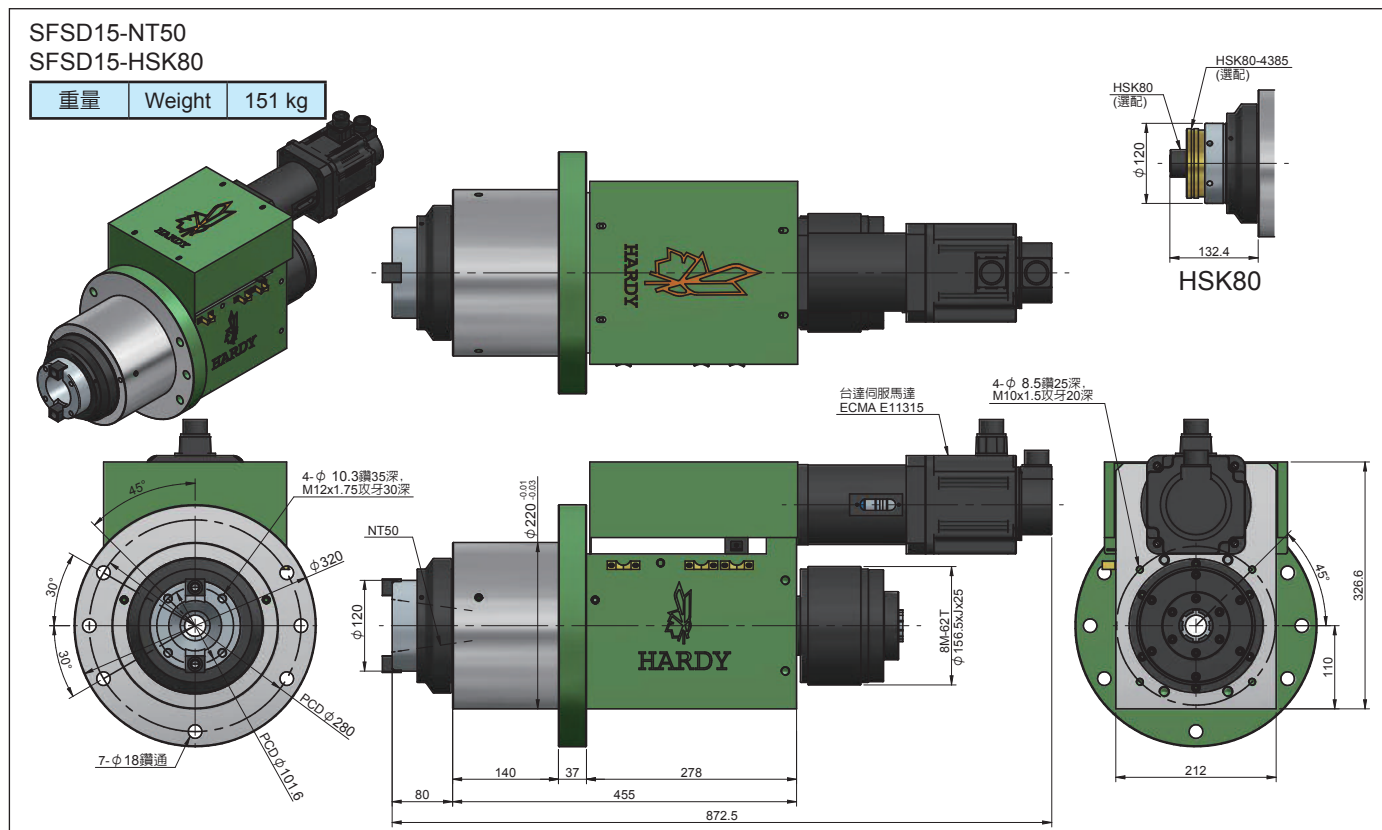

# 5011# SFSD15-150 水車伺服鑽孔/攻牙動力頭 Drilling/Tapping Spindle Head-Servo /Flange Type

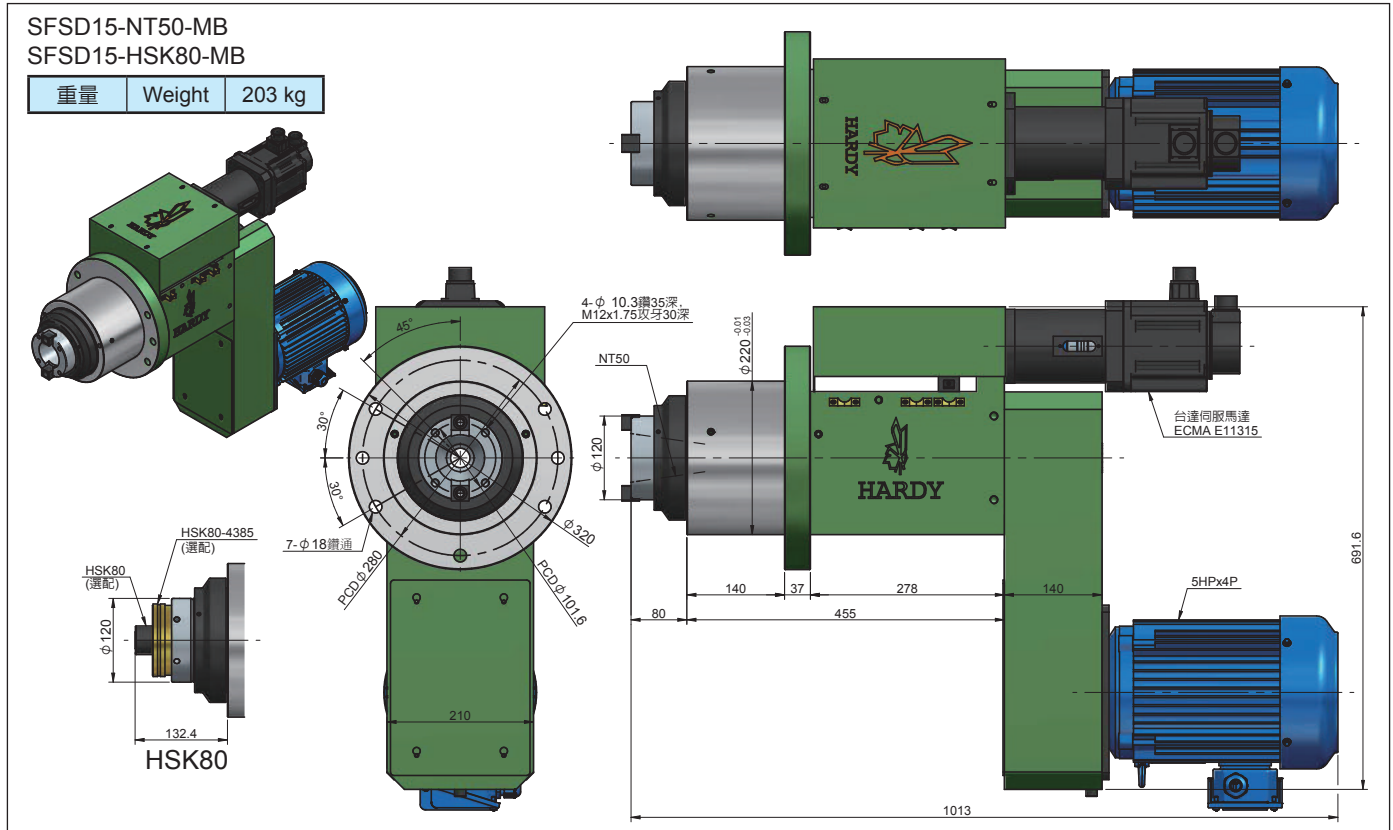

可接受特殊規格動力頭訂製  
We accept Special Spindle Unit Order

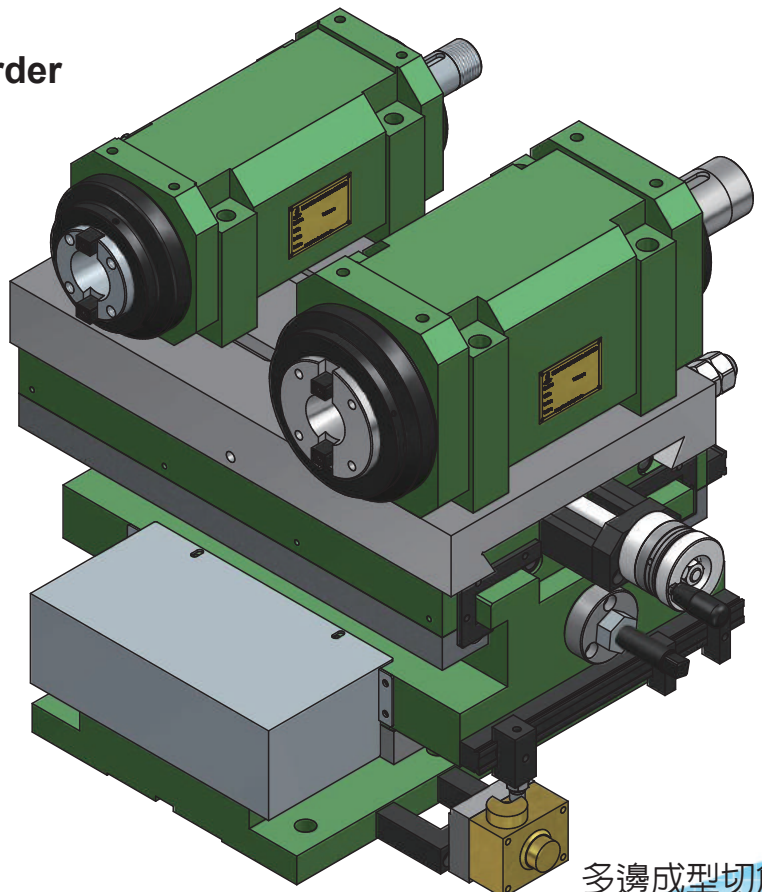
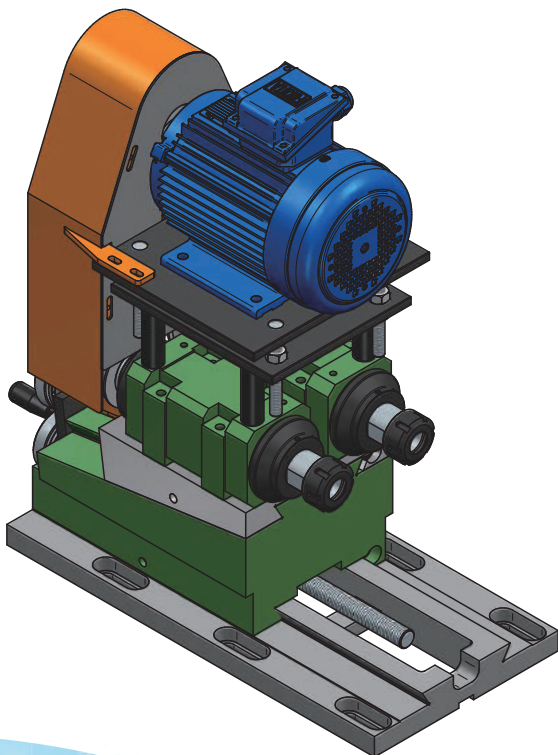

多邊成型切角機