



# 5034# SR35 搪銑主軸頭

## Boring & Milling Head Unit

SR35-NT30-MF

重量	Weight	43 kg
----	--------	-------

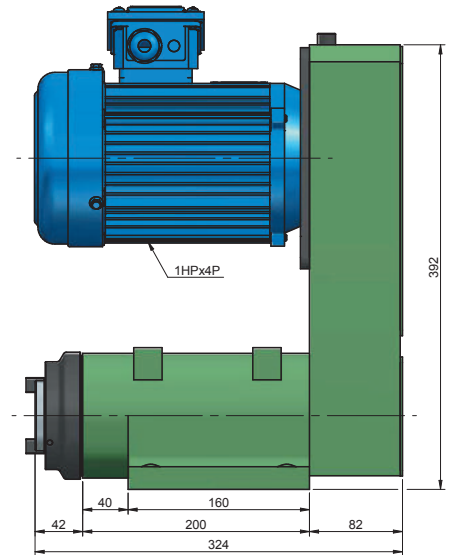
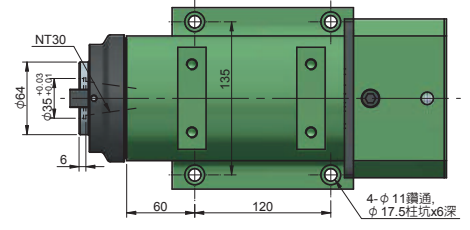
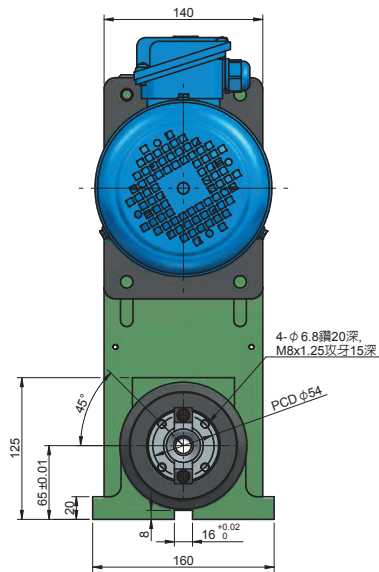
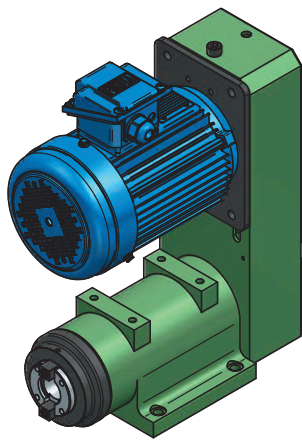

SR35-NT30-MB

重量	Weight	43 kg
----	--------	-------

