

## 5035# SR45 搪銑主軸頭 Boring & Milling Head Unit

規格	Model	SR45	SR45H
主軸	Spindle	NT40	
最高轉速	Max. RPM	2000	6000
軸承	Bearing	32209×1 / 6209Z×1 32208×1 / 6208Z×1	7209×2 7208×2
真圓度	Roundness	Within 0.003mm 內	
最大動力	Max. Power	Within 3 HP 內	
溫升	Rising Temperature	Within 20°C 內	

★出廠附精度檢驗表

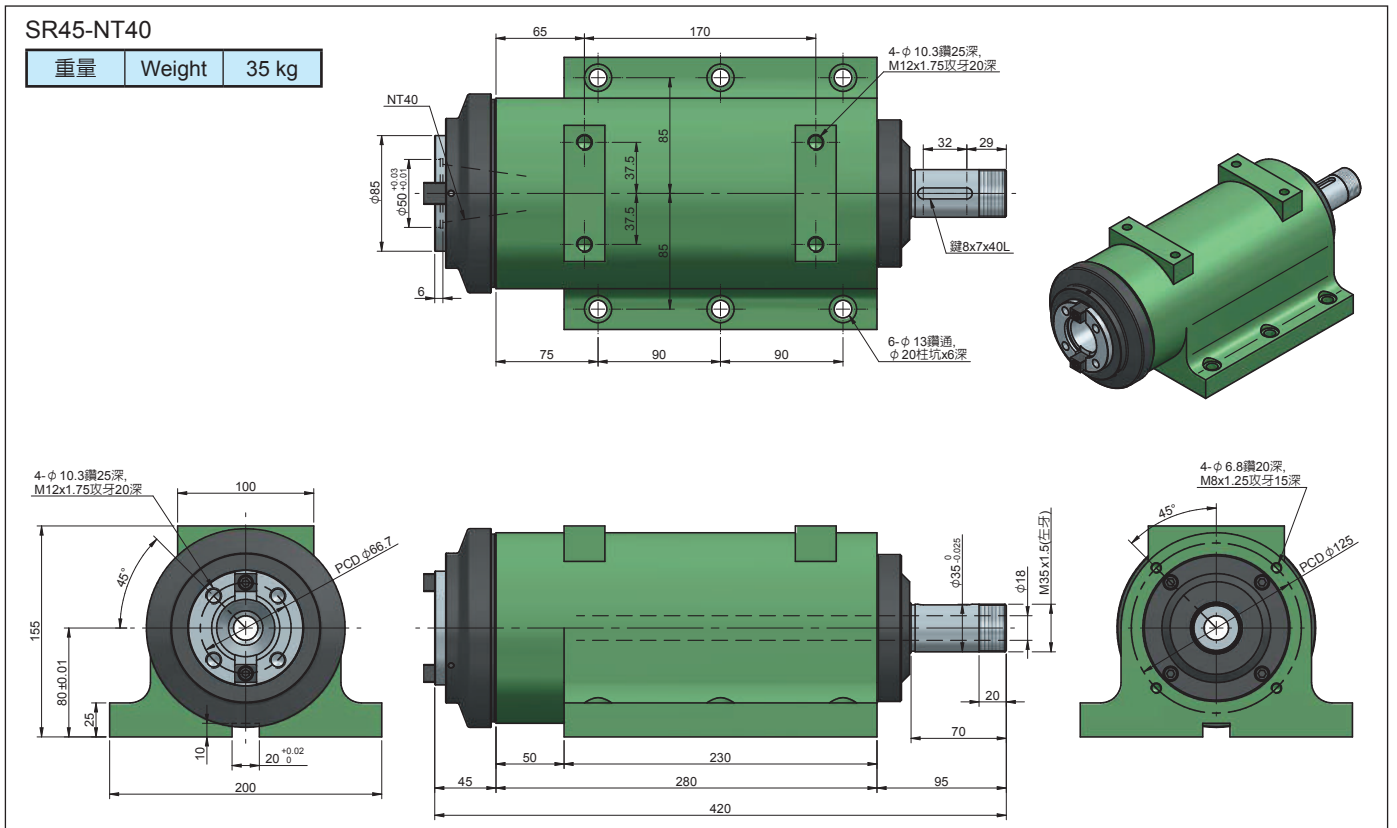

# 5035# SR45 搪銑主軸頭

## Boring & Milling Head Unit

SR45-NT40-MF

重量	Weight	72 kg
----	--------	-------

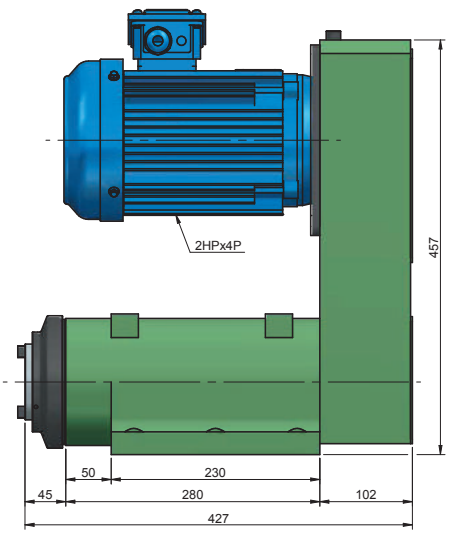
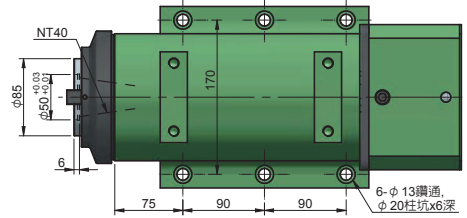
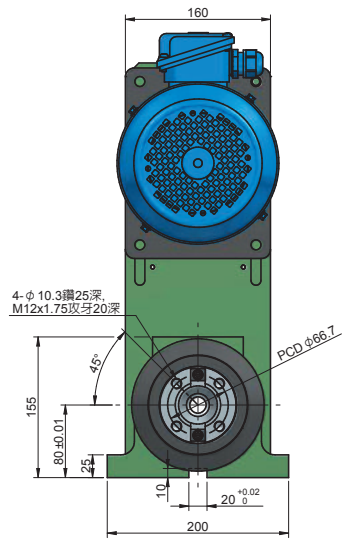
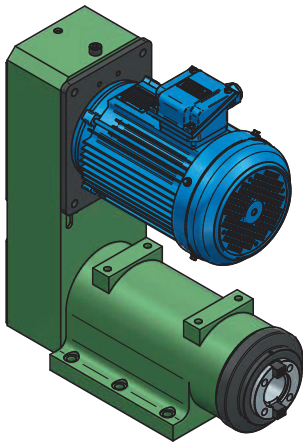

SR45-NT40-MB

重量	Weight	72 kg
----	--------	-------

