

5037# SR80 搪銑主軸頭

Boring & Milling Head Unit

規格	Model	SR80	SR80H
主軸	Spindle	NT50 or A2-5 or FB75	
最高轉速	Max. RPM	1200	3000
軸承	Bearing	32216×2 6216Z×2	7216×4
真圓度	Roundness	Within 0.003mm 內	
最大動力	Max. Power	Within 7.5 HP 內	
溫升	Rising Temperature	Within 20°C 內	

★出廠附精度檢驗表

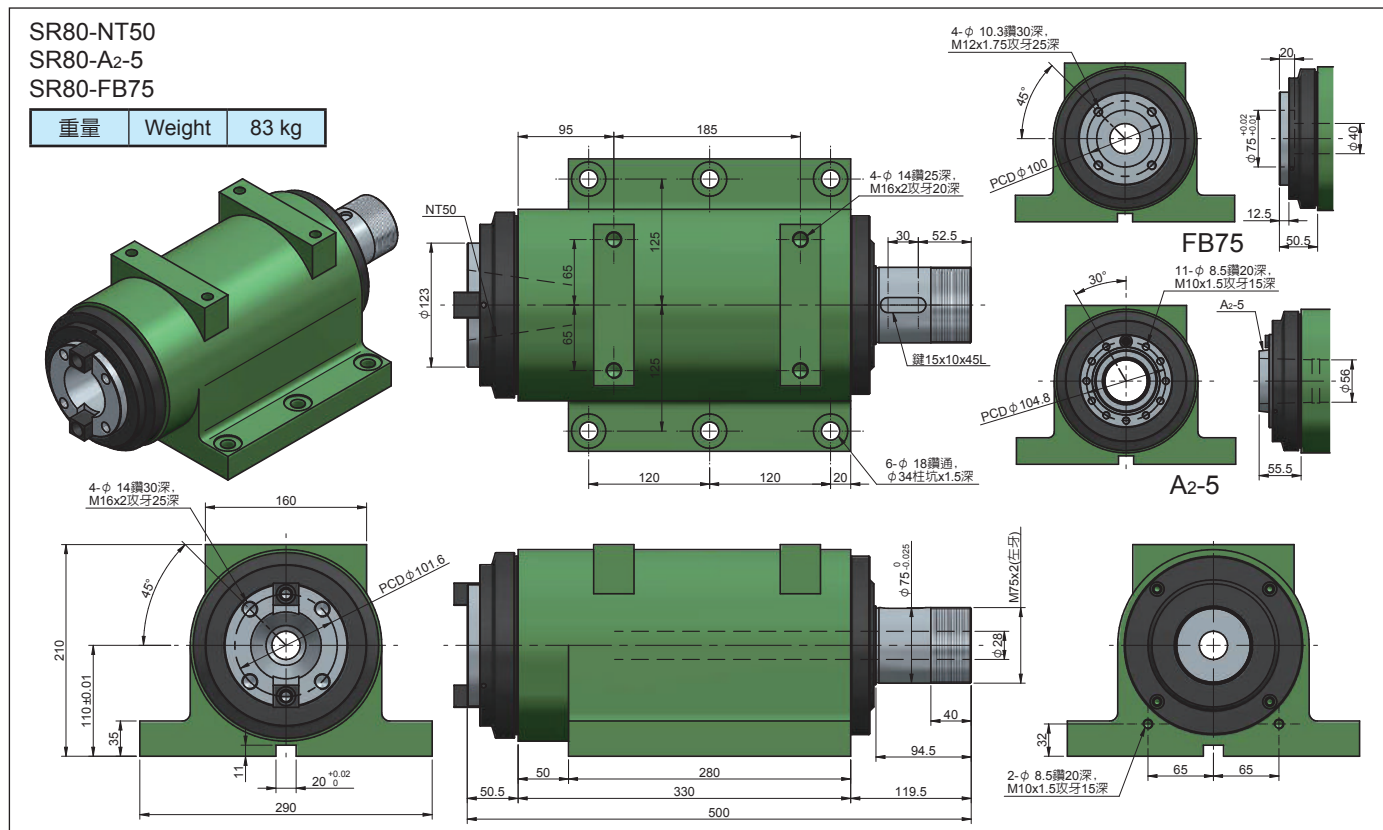

5037# SR80 搪銑主軸頭

Boring & Milling Head Unit

