

5002# SSD05-85 伺服鑽孔/攻牙動力頭 Drilling/Tapping Spindle Head-Servo Type

規格	Model	SSD05
鑽孔能力	Drilling Capacity(S45C)	φ 13
最大行程	Max. Stroke	85mm
最高轉速	Max. RPM	5000
馬力	Horsepower	1HP×4P
主軸皮帶輪	Spindle Pulley	5M-615
主軸軸承	Spindle Bearing	6004ZZ×4
皮帶輪軸承	Pulley Bearing	6203ZZ×3
螺桿軸承座軸承	Bearing Of Ballscrew Bearing Block	7001×2
螺桿軸承座油封	Seal Of Ballscrew Bearing Block	TC15-24-5×1 , TC18-30-6×1
前蓋油封	Front Cover Seal	TC60-70-10×1
主軸油封	Spindle Seal	DH-28-36-6 / 4.5×1
滾珠螺桿	Ball screw	φ 16×5×C5

Roundness: ≤ 0.003mm

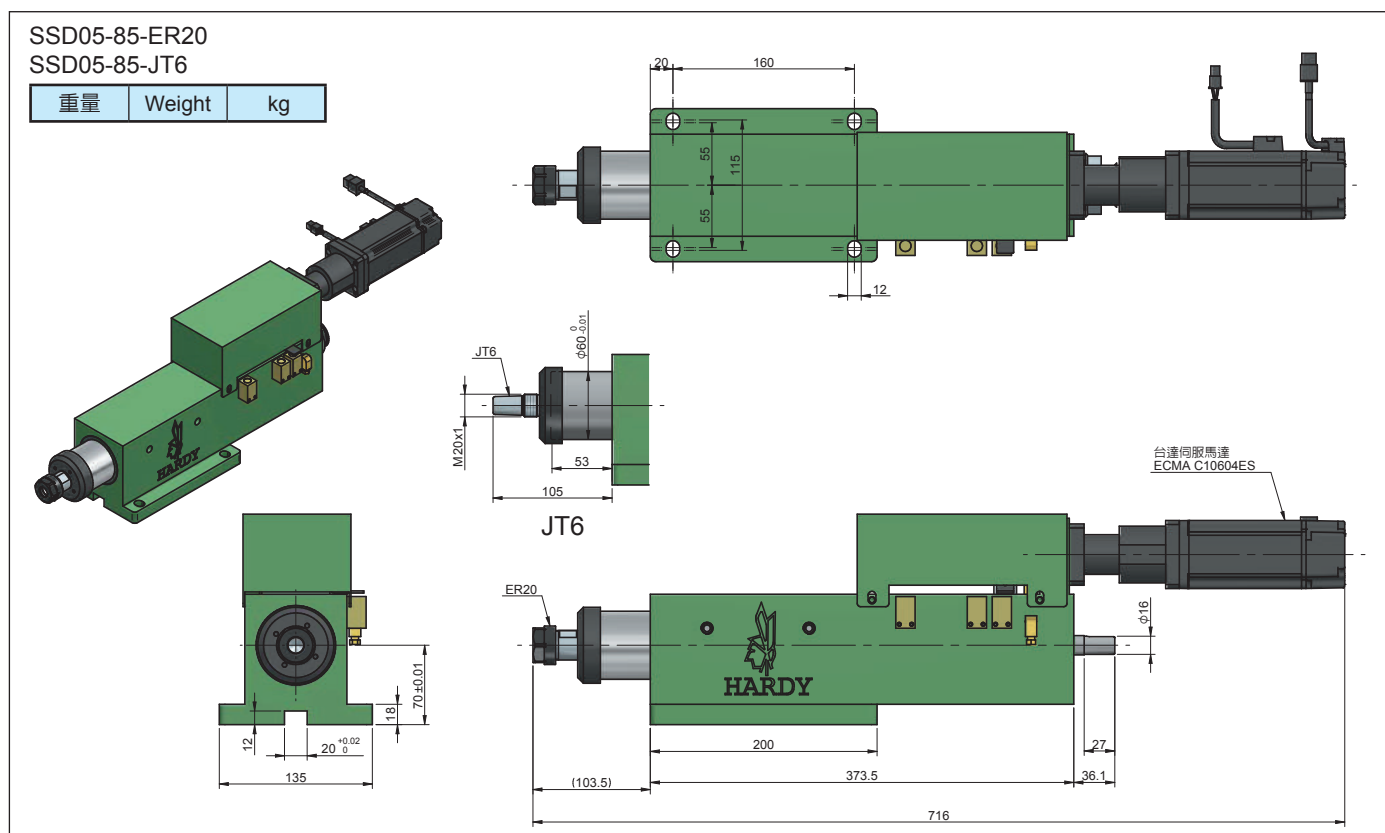

5002# SSD05-85 伺服鑽孔/攻牙動力頭 Drilling/Tapping Spindle Head-Servo Type

SSD05-85-ER20-MF
SSD05-85-JT6-MF

重量	Weight	kg
----	--------	----

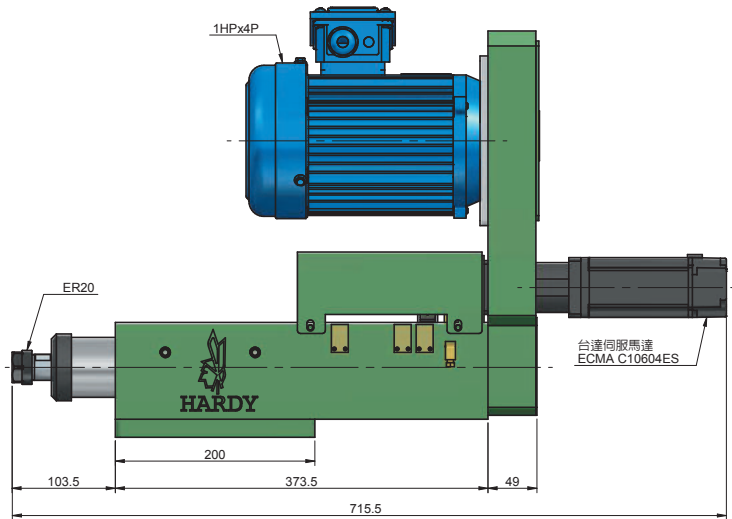
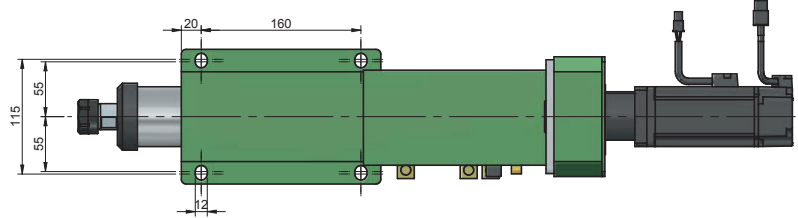
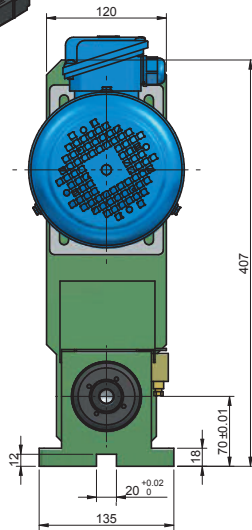
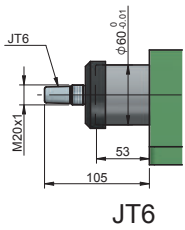
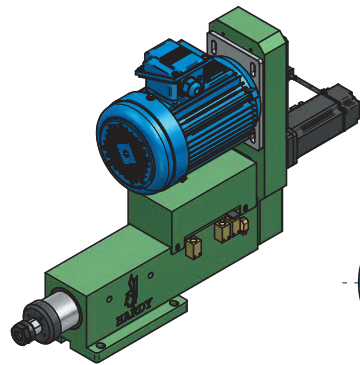

SSD05-85-ER20-MB
SSD05-85-JT6-MB

重量	Weight	kg
----	--------	----

