

## 5004# SSD09-120 伺服鑽孔/攻牙動力頭 (專利號碼 : M446677) Drilling/Tapping Spindle Head-Servo Type (Patent No. M446677)

規格	Model	SSD09	SSD09H
鑽孔能力	Drilling Capacity(S45C)	φ25	
最大行程	Max. Stroke	120mm	
最高轉速	Max. RPM	3000	8000
馬力	Horsepower	2HP×4P	
主軸皮帶輪	Spindle Pulley	5M-66T, φ 102.3×J×20	
主軸軸承	Spindle Bearing	6007Z×1 / 6006Z×1 32007×1 / 32006×1	7007×2 7006×2
皮帶輪軸承	Pulley Bearing	6010ZZ×2	
螺桿軸承座軸承	Bearing Of Ballscrew Bearing Block	7203×2	
螺桿軸承座油封	Seal Of Ballscrew Bearing Block	TC24-38-8×1 / TC24-40-8×1	
前蓋油封	Front Cover Seal	TC90-110-12×1	
主軸油封	Spindle Seal	TC50-65-8×1	
滾珠螺桿	Ball screw	φ20×5×C5	

Roundness: ≤ 0.003mm

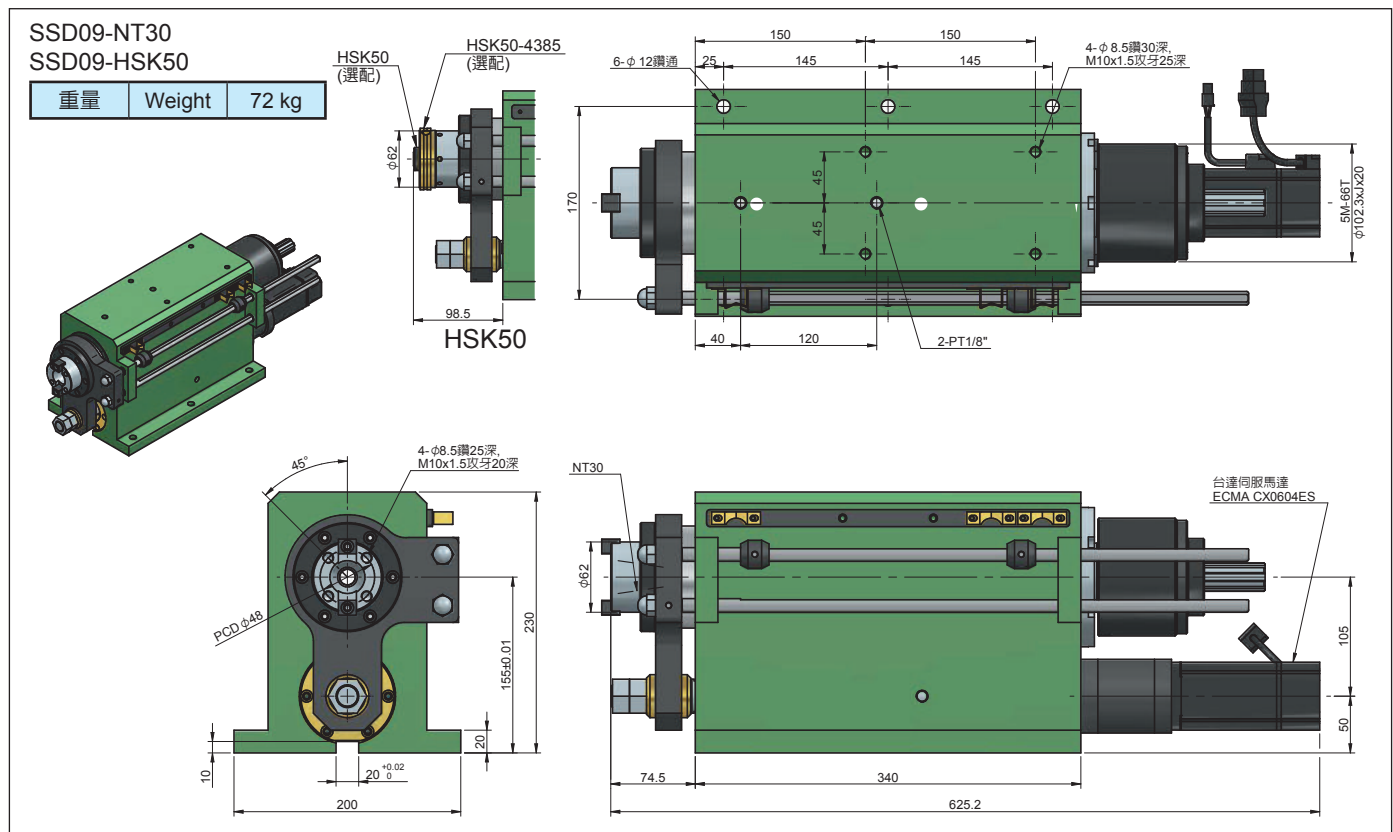

5004# SSD09-120 伺服鑽孔/攻牙動力頭 (專利號碼: M446677)  
 Drilling/Tapping Spindle Head-Servo Type (Patent No. M446677)

SSD09-NT30-MF  
 SSD09-HSK50-MF

重量	Weight	112 kg
----	--------	--------

台灣精品  
 TAIWAN EXCELLENCE  
 2017

6-φ12鑽通  
 25 150 145 150 4.5 4.5 4-φ8.5鑽30深, M10x1.5攻牙25深  
 170 40 120 2-PT1/8"

4-φ8.5鑽25深, M10x1.5攻牙20深

2HPx4P

NT30

台達伺服馬達 ECMA CX0604ES

516

105

50

74.5 340 625.2

HSK50 (選配)

φ62

HSK50-4385 (選配)

φ62

98.5

HSK50

140

45°

PCD φ48

230

155±0.01

20

10 20<sup>+0.02</sup> 200

SSD09-NT30-MB  
 SSD09-HSK50-MB

重量	Weight	112 kg
----	--------	--------

台灣精品  
 TAIWAN EXCELLENCE  
 2017

6-φ12鑽通  
 25 150 145 150 4.5 4.5 4-φ8.5鑽30深, M10x1.5攻牙25深  
 170 40 120 2-PT1/8"

4-φ8.5鑽25深, M10x1.5攻牙20深

2HPx4P

NT30

台達伺服馬達 ECMA CX0604ES

516

105

50

74.5 340 791.5

HSK50 (選配)

φ62

HSK50-4385 (選配)

φ62

98.5

HSK50

140

45°

PCD φ48

230

155±0.01

20

10 20<sup>+0.02</sup> 200