

## 5005# SSD12-150 伺服鑽孔/攻牙動力頭(專利號碼：M446677) Drilling/Tapping Spindle Head-Servo Type (Patent No. M446677)

規格	Model	SSD12	SSD12H
鑽孔能力	Drilling Capacity(S45C)	φ 35	
最大行程	Max. Stroke	150mm	
最高轉速	Max. RPM	2000	6000
馬力	Horsepower	3HP×4P	
主軸皮帶輪	Spindle Pulley	8M-54T, φ 133.6×J×25	
主軸軸承	Spindle Bearing	6011Z×1 / 6009Z×1 32011×1 / 32009×1	7011×2 7009×2
皮帶輪軸承	Pulley Bearing	6211ZZ×2	
螺桿軸承座軸承	Bearing Of Ballscrew Bearing Block	7204×2	
螺桿軸承座油封	Seal Of Ballscrew Bearing Block	TC26-42-8×2	
前蓋油封	Front Cover Seal	TC120-145-12×1	
主軸油封	Spindle Seal	TC75-90-12×1	
滾珠螺桿	Ball screw	φ 25×5×C5	

Roundness: ≤ 0.003mm

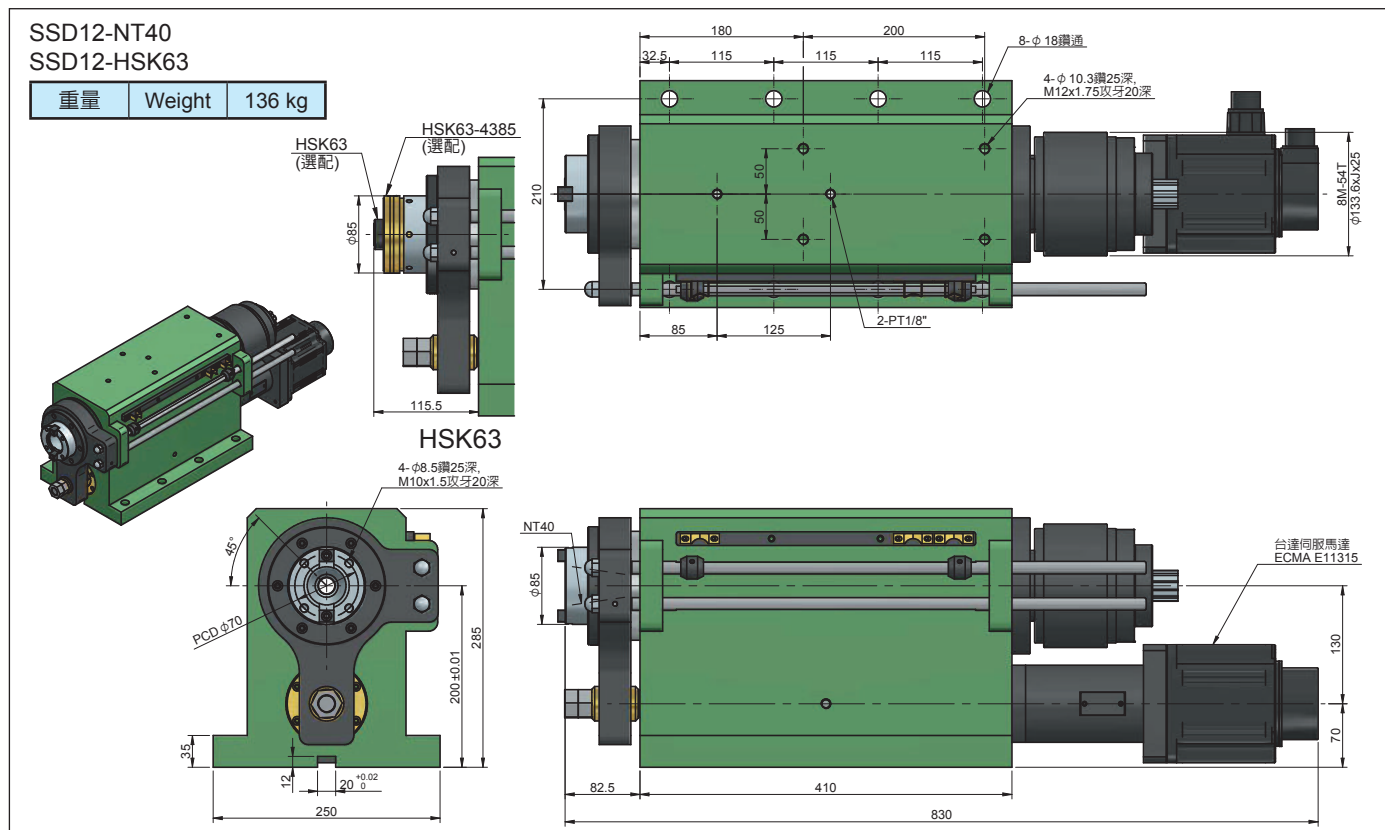

# 5005# SSD12-150 伺服鑽孔/攻牙動力頭 (專利號碼：M446677) Drilling/Tapping Spindle Head-Servo Type (Patent No. M446677)

SSD12-NT40-MF  
SSD12-HSK63-MF

重量	Weight	205 kg
----	--------	--------

台灣精品  
TAIWAN EXCELLENCE  
2017

Dimensions and Callouts:  
 - Top view: 180, 200, 32.5, 115, 115, 115, 8-φ18鑽通, 4-φ10.3鑽25深, M12x1.75攻牙20深, 2-PT1/8", 210, 85, 125.  
 - Side view: 175, 4-φ8.5鑽25深, M10x1.5攻牙20深, 45°, PCD φ70, 285, 200±0.01, 35, 12, 20<sup>+0.02</sup>/<sub>0</sub>, 250.  
 - Front view: 3HPx4P, NT40, φ85, 82.5, 410, 830, 678.5, 130, 70, 台達伺服馬達 ECMA E11315.

Options: HSK63 (選配), HSK63-4385 (選配).

SSD12-NT40-MB  
SSD12-HSK63-MB

重量	Weight	205 kg
----	--------	--------

台灣精品  
TAIWAN EXCELLENCE  
2017

Dimensions and Callouts:  
 - Top view: 180, 200, 32.5, 115, 115, 115, 8-φ18鑽通, 4-φ10.3鑽25深, M12x1.75攻牙20深, 2-PT1/8", 210, 85, 125.  
 - Side view: 175, 4-φ8.5鑽25深, M10x1.5攻牙20深, 45°, PCD φ70, 285, 200±0.01, 35, 12, 20<sup>+0.02</sup>/<sub>0</sub>, 250.  
 - Front view: 3HPx4P, NT40, φ85, 82.5, 410, 942.5, 678.5, 130, 70, 台達伺服馬達 ECMA E11315.

Options: HSK63 (選配), HSK63-4385 (選配).