

5009# SSFD11-120 水車伺服鑽孔/攻牙動力頭 Drilling/Tapping Spindle Head-Servo /Flange Type

規格	Model	SSFD11-120M-NT40	SSFD11H-120M-NT40
鑽孔能力	Drilling Capacity(S45C)	φ 35	
最大行程	Max. Stroke	120mm	
最高轉速	Max. RPM	1800	4000
馬力	Horsepower	3HP×4P	
主軸皮帶輪	Spindle Pulley	8M-64T	
主軸軸承	Spindle Bearing	6210ZZ×2 / 30210×2	7210×4
皮帶輪軸承	Pulley Bearing	6015ZZ×2	
螺桿軸承座軸承	Bearing Of Ballscrew Bearing Block	7203×2	
螺桿軸承座油封	Seal Of Ballscrew Bearing Block	TC24-40-8×1 / TC24-38-8×1	
前蓋油封	Front Cover Seal	TC110-130-13×1	
前蓋O型環	Front Cover O-ring	G85×1 / G110×1	
主軸油封	Spindle Seal	TC70-90-12×1	
活塞O型環	Piston O-ring	P110×2	
滾珠螺桿	Ball Screw	φ 25×5×C5	

Roundness: ≤ 0.003mm

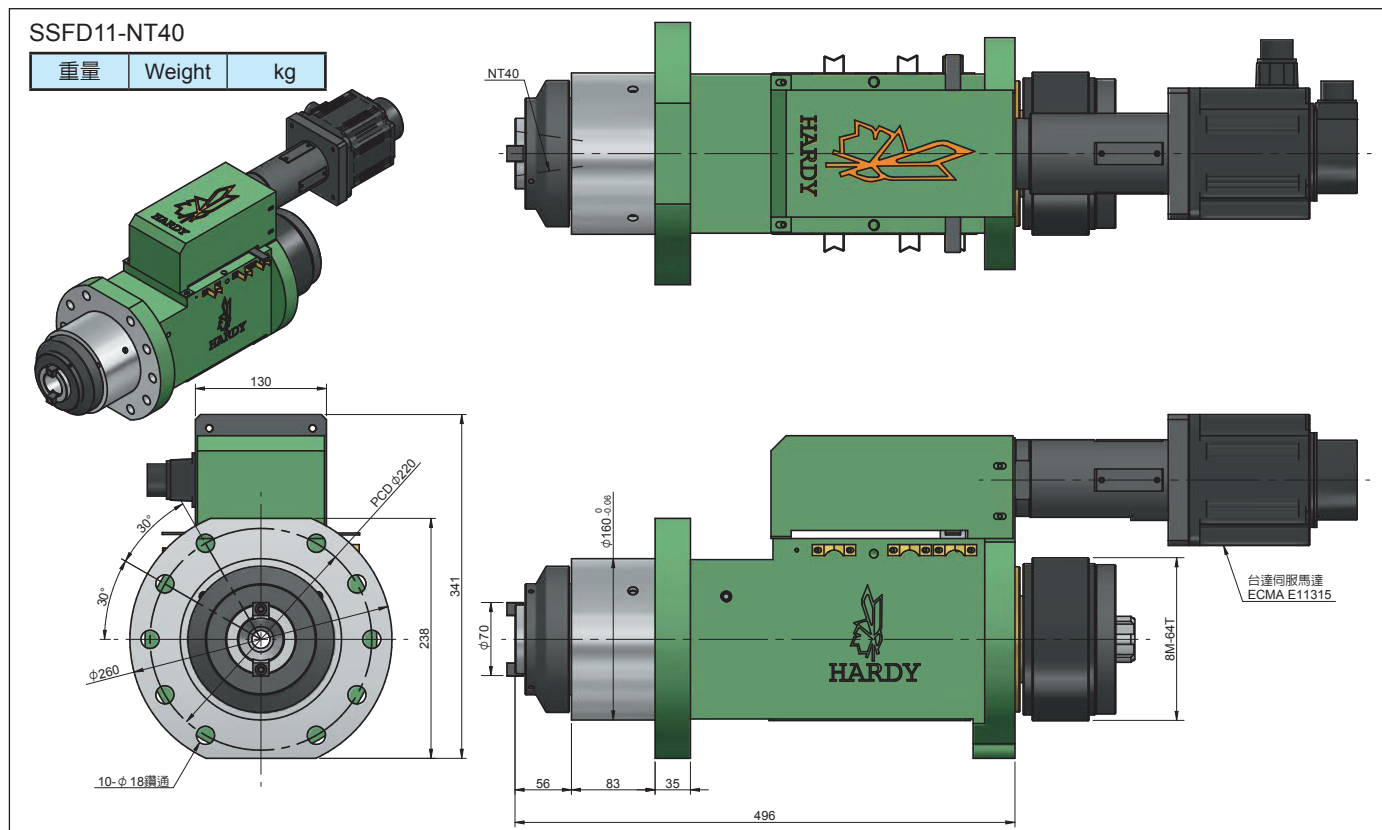

5009# SSFD11-120 水車伺服鑽孔/攻牙動力頭
Drilling/Tapping Spindle Head-Servo /Flange Type

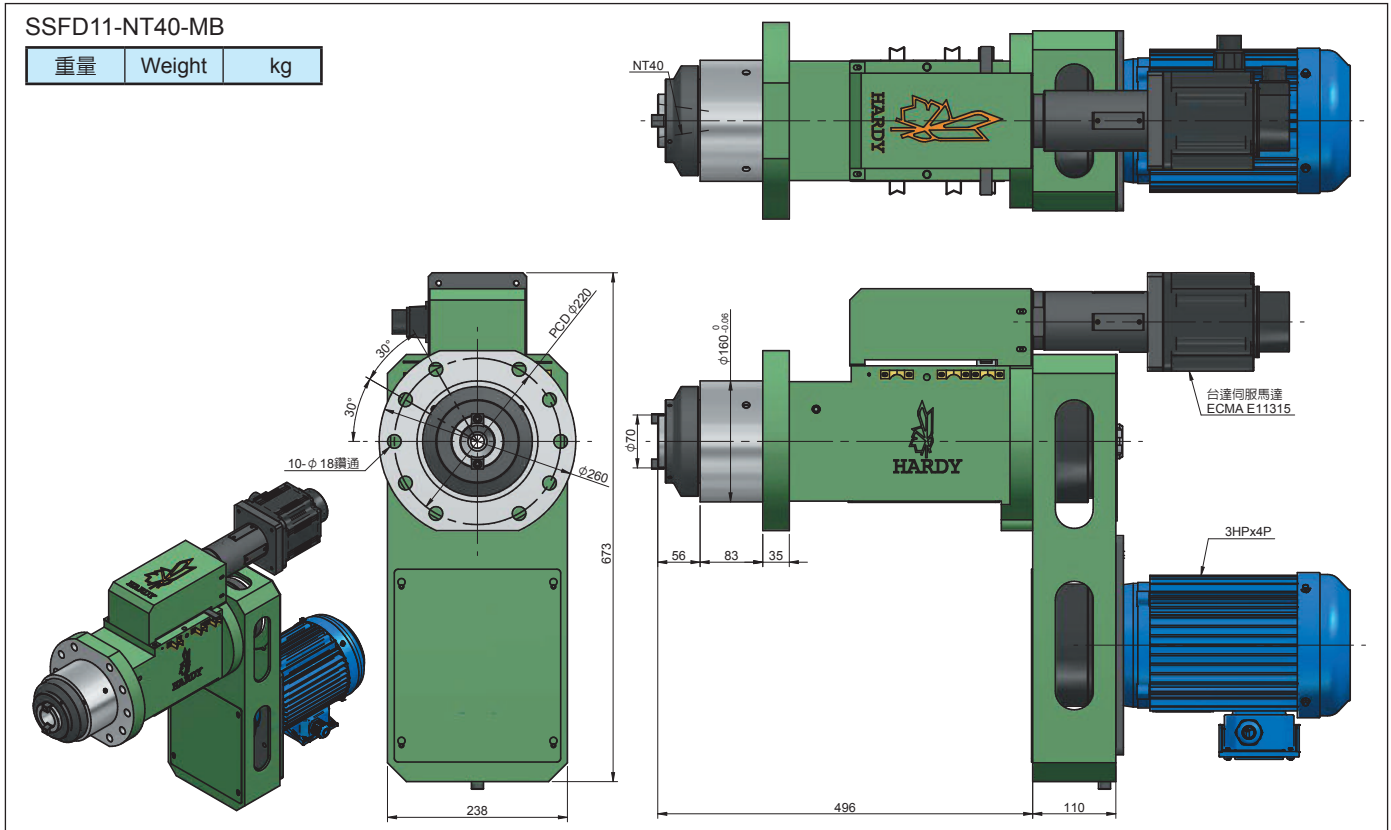

SSFC11-120 水車伺服鑽孔/攻牙動力頭/氣動打刀缸
Drilling/Tapping Spindle Head-Servo /Flange Type / with Unclamping Cylinder

