

5022# SSFSD09-120 水車伺服展刀動力頭(專利號碼:M510810)
Facing Spindle Head-Servo / Flange Type (Patent No.M510810)

規格	Model	SSFSD09-120M-NT30
最大行程	Max. Stroke	120mm
最高轉速	Max. RPM	1600
馬力	Horsepower	3HP×4P
主軸皮帶輪	Spindle Pulley	5M-66T
主軸軸承	Spindle Bearing	6007Z×1 / 6006Z×1 32007×1 / 32006×1
皮帶輪軸承	Pulley Bearing	6010ZZ×2
前蓋油封	Front Cover Seal	TC90-110-12×1
主軸油封	Spindle Seal	TC50-65-8×1
活塞O型環	Piston O-ring	P90×2
防水蓋O型環	Front Cover O-ring	G62×1 / G90×1
進給螺桿	Spindle Feeding Ball Screw	φ 20×5×C5
展刀螺桿	Facing Head Slider Ball Screw	φ 20×5×C5
螺桿軸承座軸承	Bearing Of Ballscrew Bearing Block	7203×4
螺桿軸承座油封	Seal Of Ballscrew Bearing Block	TC20-40-8×2 / TC24-38-8×2
展刀軸承座軸承	Bearing Of Facing Head	7207×2 / 7203×2
展刀軸承座油封	Seal Of Facing Head	TC45-70-8×1 TC20-40-8×1 / TC24-38-8×1
展刀搪溝頭	Single-Slide Facing Head	FA-408
滑座行程	Slider Stroke	8 mm

Roundness: ≤0.003mm
Slider Self-Repeatability: ≤0.005mm (展刀靜態重複定位)

可接受特殊規格動力頭訂製
We accept Special Spindle Unit Order
臥式四軸深孔加工(槍鑽)

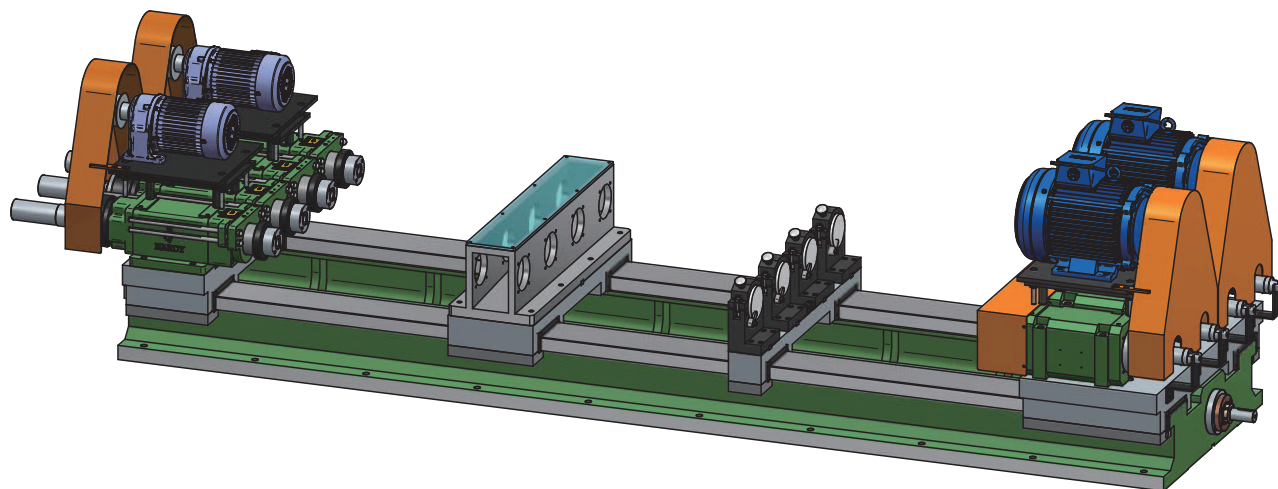

5022# SSFSD09-120 水車伺服展刀動力頭(專利號碼:M510810)
Facing Spindle Head-Servo / Flange Type (Patent No.M510810)

SSFSD09-NT30

重量	Weight	kg
----	--------	----

台灣精品
TAIWAN EXCELLENCE
2017

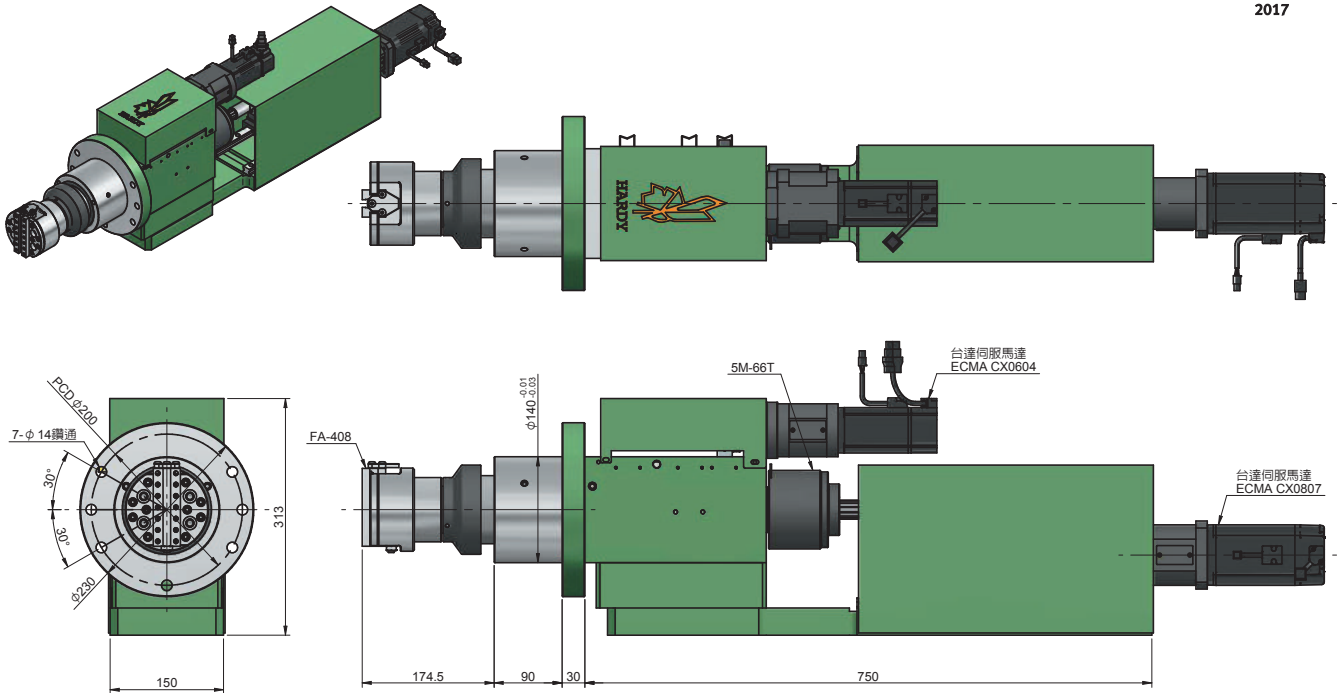

SSFSD09-NT30-MB

重量	Weight	kg
----	--------	----

台灣精品
TAIWAN EXCELLENCE
2017

