

5073# ST1N-65 攻牙主軸頭 Tapping Head Units

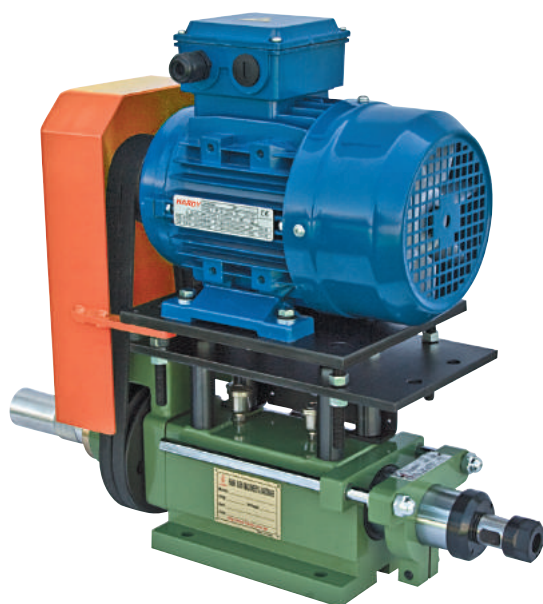

馬達架組合

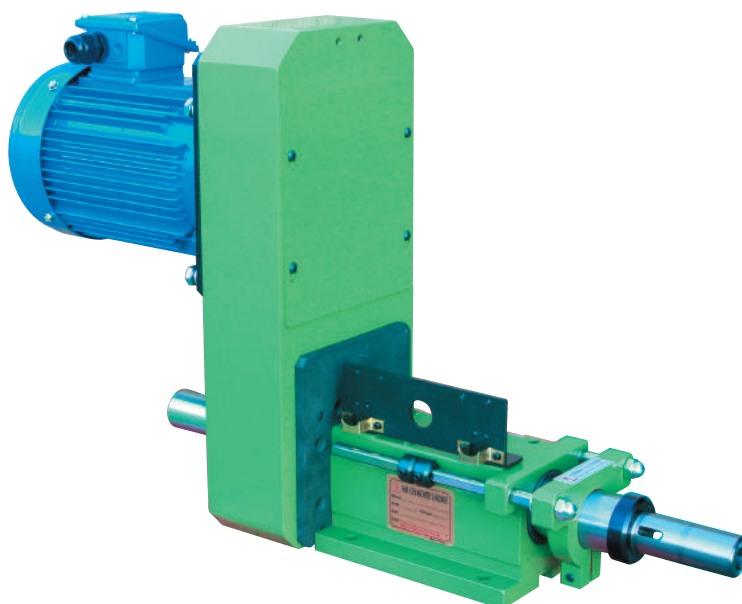

馬達盒組合

規格	Model	ST1N-65
攻牙能力	Tapping Capacity (S45C)	M12
最大行程	Max. Stroke	65 mm
螺旋導程	Thread Guide Pitch	0.4 ~ 2.0 mm
馬力	Horsepower, 3 Phase	1 HP , 220V/380V
總重	Net Weight	42 kg
主軸軸承	Spindle Bearing	6004ZZ×3
皮帶輪軸承	Pulley Bearing	6006ZZ×3
主軸油封	Spindle Seal	TC25×42×8 , TC50×62×10
傳動皮帶	Transmission Belt	A25×φ 125 , 8M×47T×33W

Roundness: $\leq 0.003\text{mm}$

5073# ST1N-65 攻牙主軸頭 Tapping Head Units

ST1N-65-ER20-R(右向)-MF
ST1N-65-ER20-L(左向)-MF

重量	Weight	39 kg
----	--------	-------

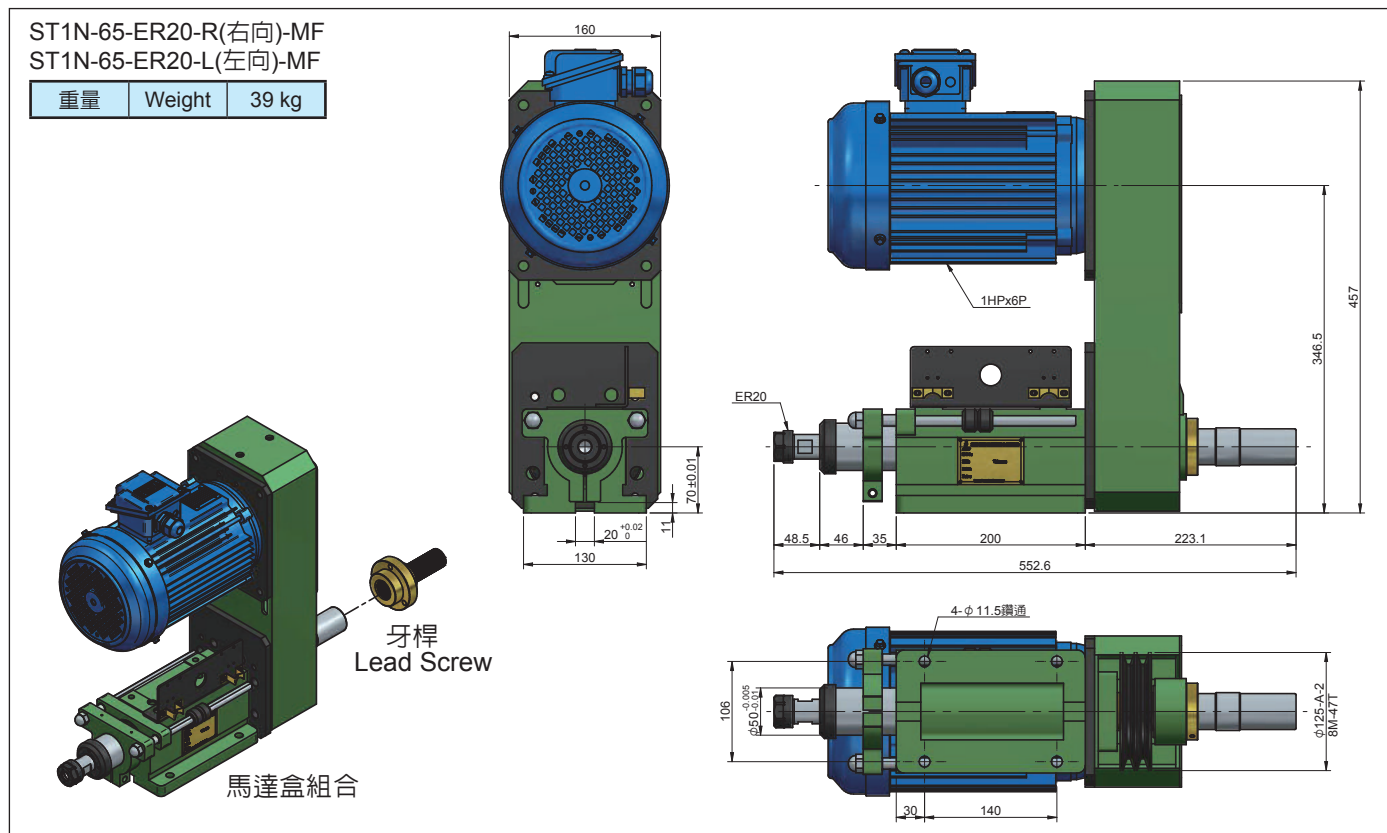

馬達盒組合

牙桿
Lead Screw

ST1N-65-ER20-R(右向)-MB
ST1N-65-ER20-L(左向)-MB

重量	Weight	39 kg
----	--------	-------

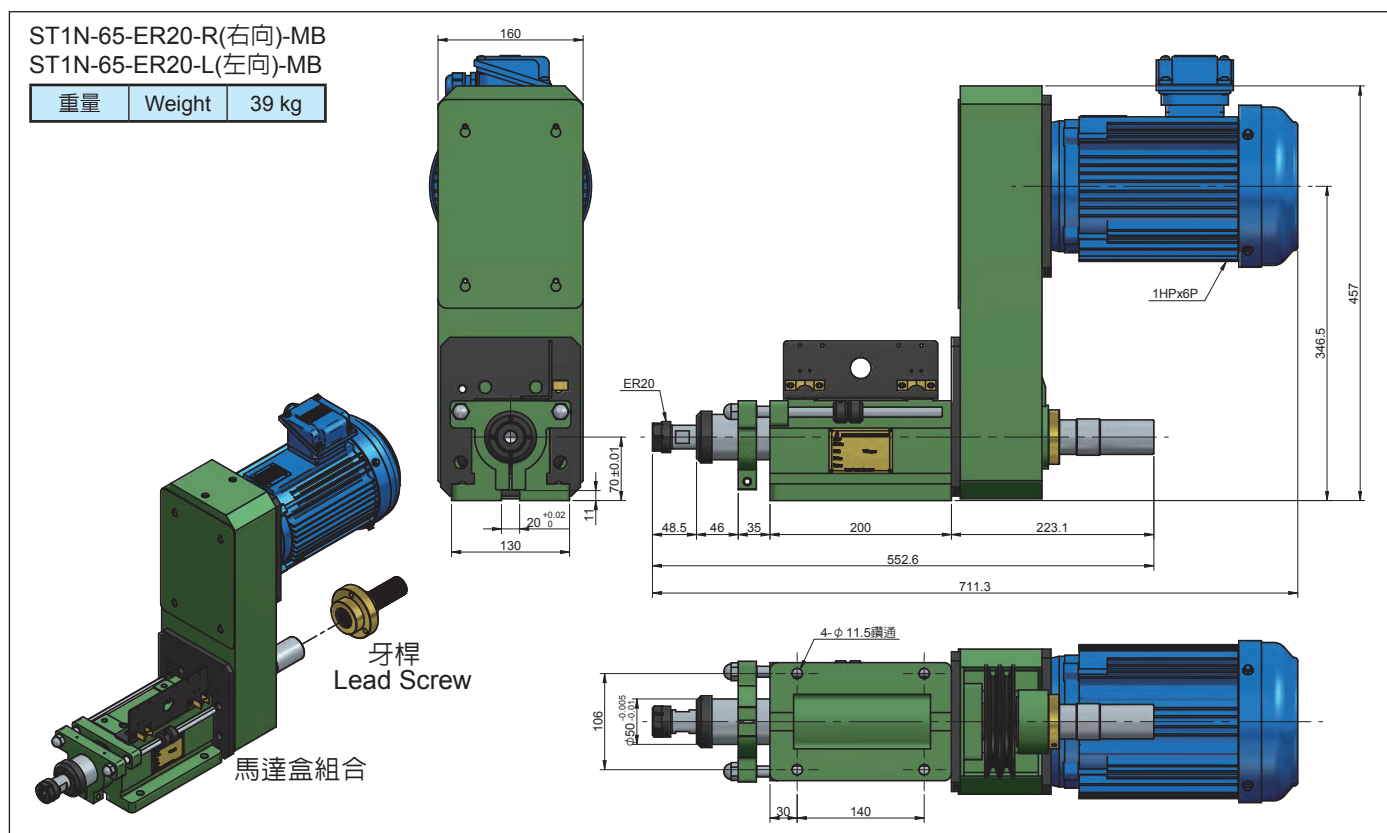

馬達盒組合

牙桿
Lead Screw

5073# ST1N-65 攻牙主軸頭 Tapping Head Units

ST1N-65-ER20-AR(右向)
ST1N-65-ER20-AL(左向)

重量	Weight	42 kg
----	--------	-------

