

5102# 空油壓分度盤 Pneumatic / Hydraulic Index Table

訂購時請註明：

1. 分割等份。
2. 空壓或油壓推送。
3. 不等分分割為特殊訂製加價。
4. 逆時針轉向加價。

Features

1. To reduce the impact, bumper is attached.
2. Tolerate heavy torque with no deviation.
3. Simple operation, the whole system can be controlled by air signal, hydraulic pressure signal or electrical signal.
4. Automate the production and to integrate with tapping, milling, riveting machines, air and hydraulic presses.
5. Easy to adjust in standard divisions 4, 8, 12 and 24.
6. Special divisions are available upon request.

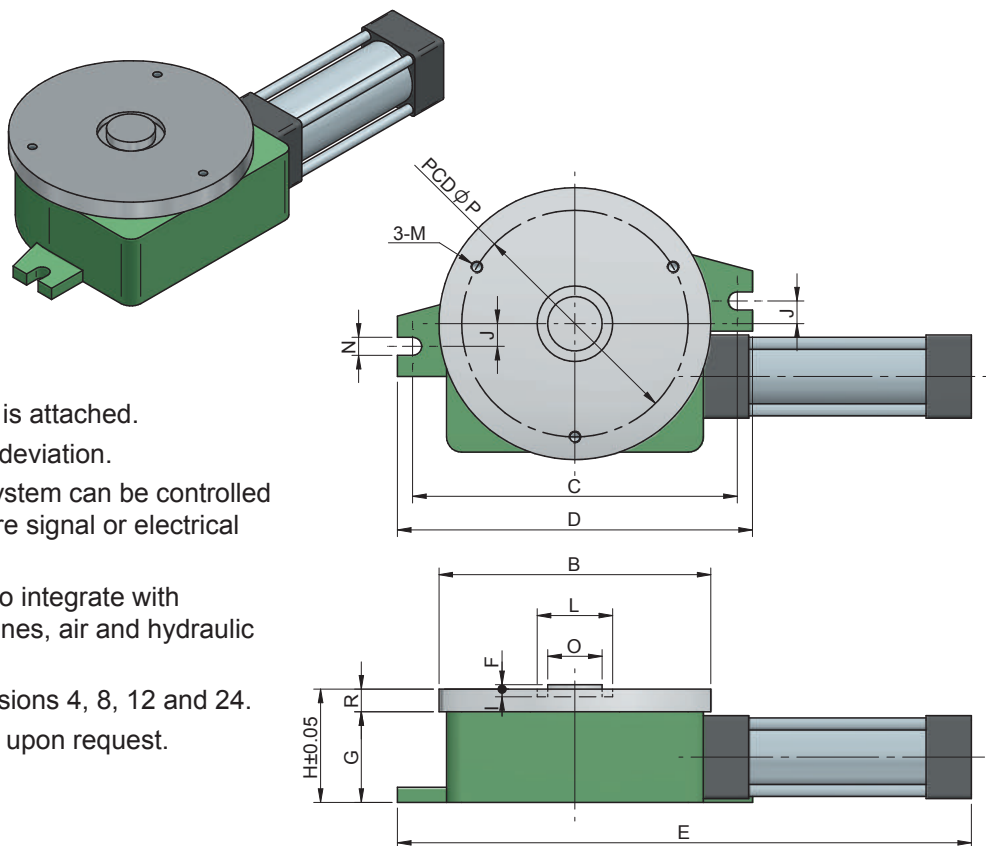

Model	尺寸 (四等份) A (氣缸)	B	C	D	E	F	G	H	I	J	L	M	N	O	P	R
TY-180	φ 40×75 \varnothing	180	215	235	380	6	60	75	3	15	50	M8×P1.25	12	36	150	15
TY-250	φ 63×100 \varnothing	250	280	300	470	8	80	104	3	20	80	M10×P1.5	15	50	200	24
TY-320	φ 80×140 \varnothing	320	360	385	595	9	100	127	3	20	100	4-M M10×P1.5	20	58	260	27

規 格 Model	TY-180	TY-250	TY-320
使用動力 Power	空壓 6kg/cm ² 或油壓 15kg/cm ² 選一		
盤 徑 Dimeter	φ 180	φ 250	φ 320
最大載重 Max. Load	50 kg	100 kg	200 kg
迴轉方向 Direction	順時或逆時方向選一 Clock-wise or Counter Clock-wise		
分 割 數 Index Number	4, 6, 8, 12, 24 選一或特殊訂製		
分割精度 Accuracy	± 0.02 m/m	± 0.02 m/m	± 0.02 m/m
定位方式 Position Drive	棘輪式 Ratchet Drive		
重 量 Weight	11	28	58
主軸貫穿孔 Spindle hole	0	0	0